



BERNINA 770 QE PLUS

User Manual

Dear BERNINA customer,



Congratulations! You have decided on BERNINA and therefore on a product which will delight you for years. For more than 100 years our family company has attached greatest importance to satisfied customers. As for me, it is a matter of personal concern to offer you Swiss development and precision at the height of perfection, future-orientated sewing technology and a comprehensive customer service.

The BERNINA 7-series consists of various ultramodern machines, whose development not only focused the highest demands on technique and the ease of use but also considered the design of the product. After all we sell our products to creative people like you, who do not only appreciate high quality but also form and design.

Enjoy the creative sewing, embroidering and quilting on your new BERNINA 770 QE PLUS and keep informed about the various accessories at www.bernina.com. On our homepage you will also find a lot of inspiring sewing instructions, to be downloaded for free.

Our highly trained BERNINA dealers will provide you with more information on service and maintenance offers.

I wish you lots of pleasure and many creative hours with your new BERNINA.



H.P. Ueltschi

Owner

BERNINA International AG

CH-8266 Steckborn

Table of Contents

IMPORTANT SAFETY INSTRUCTIONS	9	2.5 Spool Pin	33
Important Information	11	Swiveling Spool Pin	33
1 My BERNINA	13	Horizontal Spool Pin	34
1.1 Introduction	13	2.6 Feed Dog	35
1.2 BERNINA Quality Control	13	Adjusting the Feed Dog	35
1.3 Welcome to the World of BERNINA	13	2.7 Slide-on Table	35
1.4 Overview Machine	15	Using the Slide-on Table	35
Overview front controls	15	2.8 Presser Foot	36
Overview front	16	Adjusting the Presser Foot Position via the Knee Lifter of the Free Hand System	36
Overview sideways	17	Adjusting the Presser Foot Position via the Button «Presser Foot Up/Down»	36
Overview - Back panel	18	Changing the presser foot	36
1.5 Supplied Accessories	19	Selecting the Presser Foot in the User Interface	36
Overview Accessories Machine	19	Setting the Presser Foot Pressure	37
Overview Presser Feet	21	2.9 Needle and Stitch Plate	37
Accessory box	22	Changing the needle	37
1.6 Overview User Interface	23	Selecting the needle in the User Interface	38
Overview functions/visual information	23	Selecting needle type and needle size	38
Overview System settings	23	Adjusting the Needle Position Up/Down	39
Overview selection menu sewing	23	Adjusting the Needle Position Left/Right	39
Software Operation	24	Needle Stop Up/Down (Permanent)	39
1.7 Needle, Thread, Fabric	26	Changing the Stitch Plate	39
Overview Needles	26	Selecting the stitch plate in the User Interface	40
Example for Needle Description	29	2.10 Threading	40
Thread Selection	29	Threading the upper thread	40
Needle/Thread Combination	29	Threading the Twin Needle	43
2 Sewing Preparation	30	Threading the triple needle	43
2.1 Before Using the Machine for the First Time	30	Winding the bobbin thread	44
2.2 Accessories Box	30	Threading the Bobbin Thread	45
Accessory box free standing	30	Indicating Fill Level of Bobbin Thread	47
Storing accessory	30	3 Setup Program	48
2.3 Connection and Switching On	31	3.1 Sewing Settings	48
Connecting the Foot Control	31	Adjusting the Upper Thread Tension	48
Connecting the Machine	31	Adjusting the Maximum Sewing Speed	48
Attaching the Knee Lifter of the Free Hand System	32	Programming Securing Stitches	48
Fixing the Touch Screen Pen	32	Adjusting the hovering height of the presser foot	48
Switching the Machine On	32	Programming the button «Pattern end»	49
2.4 Foot Control	33	Programming the button «Thread cutter»	49
Regulating the Speed via the Foot Control	33	Adjusting the presser foot position with needle stop down	49
Activate/Deactivate Additional Function	33	Programming the button «Quick reverse»	50
		Programming the button «Securing»	50
		Programming the foot control	50
		3.2 Embroidery Settings	51



Adjusting the Upper Thread Tension	51	Programming long stitch	65
Adjusting the Maximum Embroidering Speed	51	Mirror Image of Stitch Patterns	65
Centering or opening embroidery motifs in the original position	51	Edit Stitch Pattern Length	65
Calibrating the embroidery hoop	52	Programming the Stitch Counter Function	65
Entering the fabric thickness	52	Sewing Stitch Patterns Using the Triple Stitch	65
Activating/Deactivating the function thread away	52	Quick Reverse	66
Programming the securing stitches	53	Permanent Quick Reverse	66
Adjusting the thread cut	53	Backstepping	66
Changing the measuring unit	54		
3.3 Selecting personal settings	54	5.6 Combining stitch patterns	66
3.4 Monitoring Functions	55	Overview Combi Mode	66
Activating the Upper Thread Indicator	55	Creating Stitch Pattern Combinations	66
Activating the Bobbin Thread Indicator	55	Saving a Stitch Pattern Combination	67
3.5 Activating the audio signals	55	Loading a Stitch Pattern Combination	67
3.6 Machine Settings	56	Overwriting a Stitch Pattern Combination	67
Selecting a language	56	Deleting a Stitch Pattern Combination	68
Adjusting the Brightness of the Display	56	Editing a Single Stitch Pattern	68
Adjusting the Sewing Light	56	Deleting a Single Stitch Pattern	68
Calibrating the Display	56	Adding a Single Stitch Pattern	69
Back to Basic Setting	57	Adapting the Stitch Pattern length and Stitch Pattern Width	69
Deleting user data	57	Mirroring a Stitch Pattern Combination	70
Deleting motifs on the BERNINA USB Stick	57	Stitch Pattern Combination Subdivider 1	70
Calibrating the Buttonhole Foot #3A	58	Stitch Pattern Combination Subdivider 2	71
Packing the embroidery module	58	Securing a Stitch Pattern Combination	71
Reviewing the total number of stitches	58	Programming Pattern Repeat	71
Registering details of the dealer	59	5.7 Administering Stitch Patterns	71
Saving Service data	59	Saving Settings of Stitch Patterns	71
4 System Settings	60	Calling up the previously sewn stitch patterns	72
4.1 Calling Up the Tutorial	60	Saving Stitch Patterns in Personal Memory	72
4.2 Calling up the Creative Consultant	60	Overwriting Stitch Patterns from the Personal Memory	72
4.3 Calling Up the Help	60	Loading Stitch Patterns from the Personal Memory	72
4.4 Using eco mode	60	Deleting Stitch Patterns from the Personal Memory	72
4.5 Cancelling Any Alterations with «clr»	60	Saving Stitch Patterns on the BERNINA USB Stick	73
5 Creative Sewing	61	Uploading a Stitch Pattern from the BERNINA USB Stick	73
5.1 Overview selection menu sewing	61	Deleting Stitch Patterns from the BERNINA USB Stick	73
Selecting a stitch pattern	61	5.8 Securing Stitches	73
5.2 BERNINA Dual Feed	61	Securing a seam with the button «Securing»	73
Switching on/off the BERNINA Dual Feed	62	Securing with the Button «Pattern End»	74
5.3 Regulating the Speed	62	5.9 Height Compensation of Uneven Layers	74
5.4 Adjusting the upper thread tension	63	5.10 Sewing Corners	74
5.5 Editing Stitch Patterns	63	6 Practical Stitches	76
Changing the Stitch Width	63	6.1 Overview Practical Stitches	76
Changing the Stitch Length	64	6.2 Sewing Straight Stitch	78
Correcting the Balance	64	6.3 Securing with the Automatic Securing Program	79
Programming Pattern Repeat	64	6.4 Sewing in the Zipper	79
		6.5 Sewing Both Sides of the Zipper from Bottom to Top	80

6.6	Sewing Triple Straight Stitch	81	9.8	Determining the buttonhole length with the Buttonhole Foot with Slide #3A	104
6.7	Sewing Triple Zigzag	81	9.9	Determining the buttonhole length with Buttonhole Foot #3C	105
6.8	Manual Darning	82	9.10	Sewing a buttonhole automatically	106
6.9	Automatic Darning	84	9.11	Programming the Heirloom Buttonhole	106
6.10	Reinforced Darning, Automatic	84	9.12	Sewing the manual 7-step buttonhole with the Buttonhole Foot #3C	107
6.11	Reinforced Darning	85	9.13	Sewing the Manual 5-step Buttonhole with the Buttonhole Foot #3C	107
6.12	Finishing Edges	86	9.14	Cutting the Buttonhole Open with the Seam Ripper	108
6.13	Sewing Double overlock	86	9.15	Cutting Open Buttonholes with the Buttonhole Cutter (Optional Accessory)	109
6.14	Narrow Edgestitching	86	9.16	Sewing on a Button	109
6.15	Wide Edgestitching	87	9.17	Sewing Eyelets	110
6.16	Edgestitching using the seam guide	87	10 Quilting	111	
6.17	Sewing hem edges	88	10.1	Overview Quilt Stitches	111
6.18	Sewing blind hems	88	10.2	Quilting, Securing Program	112
6.19	Sewing Visible Hems	89	10.3	Sewing handlook quilt stitches	112
6.20	Sewing Flat Joining Seams	89	10.4	Guiding the Quilt Work Freely	113
6.21	Sewing basting stitches	90	11 BERNINA Stitch Regulator (BSR)	114	
7 Decorative Stitches	91	11.1	BSR Mode 1	114	
7.1	Overview Decorative Stitches	91	11.2	BSR Mode 2	114
7.2	Bobbin-Play	92	11.3	BSR mode 3	114
7.3	Altering the stitch density	92	11.4	BSR Function with Straight Stitch No. 1	114
7.4	Sewing Cross Stitches	93	11.5	BSR Function with Zigzag No. 2	114
7.5	Pintucks	94	11.6	Sewing Preparations for Quilting	114
	Pintucks	94		Attach the BSR presser foot	114
	Overview Pintuck Feet	94		Changing the Presser Foot	115
	Working with Cord	95	11.7	Using the BSR Mode	115
	Sewing Pintucks	96	11.8	Securing Stitches	116
				Securing in BSR1 Mode with the Button «Start/Stop» .	116
				Securing in BSR2 Mode	116
8 Alphabets	97	11.9	Using the KickStart function	116	
8.1	Overview Alphabet	97	12 My BERNINA Embroidery	118	
8.2	Creating Lettering	97	12.1	Overview Embroidery module	118
8.3	Altering font size	98	12.2	Supplied Accessories Embroidery Module	119
				Overview Accessory Embroidery Module	119
9 Buttonholes	99	12.3	Overview User Interface	120	
9.1	Overview Buttonholes	99		Overview functions/visual information	120
9.2	Making Use of the Height Compensation Tool	100		Overview System settings	120
9.3	Using the Compensation Plate	101			
9.4	Marking Buttonholes	101			
9.5	Cord	102			
	Using Cord with the Buttonhole Foot with Slide #3A ...	102			
	Using cord with the Buttonhole Foot #3C	103			
9.6	Sewing a Test Sample	104			
9.7	Determining the Buttonhole Slit Width	104			



Overview Selection Menu Embroidery	120	14 Setup Program	134
12.4 Important Embroidery Information	121	14.1 Adjusting the Embroidery Settings in the Setup	
Upper Thread	121	Program	134
Bobbin Thread	121	15 Creative Embroidering	135
Choosing the Embroidery Design	121	15.1 Overview Embroidering	135
Selecting the Embroidery File Format	122	15.2 Selecting and Changing the Embroidery Design	135
Embroidery Test	122	15.3 Checking the Embroidery Time and the Embroidery	
The Size of the Embroidery Design	122	Design Size	135
Embroidering Designs by Third-party Providers	122	15.4 Regulating the Speed	136
Underlay Stitches	122	15.5 Editing the Embroidery Design	136
Satin or Leaf Stich	123	Overview Editing embroidery motif	136
Step Stitch	123	Scaling Up the Embroidery Design View	136
Connecting Stitches	123	Downsizing the Embroidery Design	136
13 Embroidery preparation	124	Moving the Embroidery Design View	137
13.1 Attaching the Module	124	Moving the Embroidery Design in Enlarged View	137
13.2 Preparing the Machine	124	Moving the Embroidery Design	137
Lowering the feed dog	124	Rotating the Embroidery Design	137
Selecting an embroidery motif	125	Altering the Embroidery Design Size Proportionally	138
13.3 Embroidery Foot	125	Altering the Embroidery Design Size Disproportionally	138
Attaching the embroidery foot	125	Mirroring Embroidery Designs	139
Selecting the Stitch Plate in the User Interface	125	Changing the Stitch Type	139
13.4 Needle and Stitch Plate	126	Altering the Stitch Density	140
Inserting the embroidery needle	126	Checking the Size and the Position of the Embroidery	
Selecting the embroidery needle in the User Interface	126	Design	140
Selecting needle type and needle size	127	Deleting an Embroidery Design	141
Attaching the stitch plate	127	Changing the sequence within an embroidery motif	
Selecting the stitch plate in the User Interface	128	combination	141
Thread-up Command	128	Grouping embroidery motifs	141
13.5 Embroidery Hoops	129	15.6 Pinpoint Placement	142
Overview Embroidery Hoop Selection	129	Positioning of grid points	142
Selecting the Embroidery Hoop	129	Free point positioning	143
Tear-away Stabilizers	129	15.7 Combining Embroidery Designs	144
Cut-away Stabilizers	129	Combining Embroidery Designs	144
Using Adhesive Spray	129	Deleting a Single Embroidery Design	144
Using Spray Starch	130	Duplicating the embroidery motif	145
Using Iron-on Interfacing	130	Duplicating a combination	145
Using Paper-backed Adhesive Stabilizer	130	15.8 Creating Lettering	146
Using Water-soluble Stabilizer	130	Overview embroidery alphabets	146
Preparing the Embroidery Hoop	130	Creating Lettering	146
Attaching the Hoop	131	Editing the Lettering	147
Overview Embroidery functions	132	15.9 Changing the Colors of the Embroidery Design	147
Centering the Needle to the Embroidery Hoop	132	Overview Changing the Color	147
Move Hoop to the Back	132	Changing the Colors	147
Moving the Module for the Sewing Mode	132	Changing the Thread Brand	147
Grid On/Off	133	15.10 Embroidering the Embroidery Design	148
Locating the Center of the Embroidery Design	133	Overview Embroidery menu	148
Virtual Positioning of the Embroidery Hoop	133	Adding Basting Stitches	148
		Moving the Hoop	148

Embroidery Sequence Control when the Thread Breaks	148	20	Technical data	169
Cutting Connecting Stitches	149	21	Overview Stitch Patterns	170
Reducing Color Changes	149	21.1	Overview Stitch Patterns	170
Multi-colored Embroidery Design On/Off	149		Practical Stitches	170
Color Indication	149		Buttonholes	170
15.11 Freearm Embroidery	149		Decorative Stitches	170
15.12 Administering Embroidery Designs	150		Quilt Stitches	173
Administering Embroidery Designs	150	21.2	Overview Embroidery Desings	174
Saving Embroidery Designs in the Personal Memory	150		Editing the Embroidery Design	174
Saving the Embroidery Design on the BERNINA USB Stick	151		Quilt motifs	174
Overwriting the Embroidery Design in the Personal Memory	151		Quilting in the hoop	179
Overwriting the Embroidery Design on the BERNINA USB Stick	151		Projects	181
Importing Stitch Patterns	151		Children	182
Loading an Embroidery Design from the Personal Memory	152		Animals	185
Loading an Embroidery Design from the BERNINA USB Stick	152		Borders	186
Deleting an Embroidery Design from the Personal Memory	152		Sport and hobbies	188
Deleting an Embroidery Design from the BERNINA USB Stick	152		Embellishment	189
16 Embroidery	153		Borders and Lace	192
16.1 Embroidering via the Button «Start/Stop»	153		Seasons	194
16.2 Increasing the Embroidery Speed	153		Flowers	197
16.3 Adjusting the upper thread tension	153		DesignWorks	199
16.4 Embroidering via the Foot Control	154		Index	202
17 Care and Maintenance	155			
17.1 Firmware	155			
Checking the firmware version	155			
Updating firmware	155			
Recovering saved data	155			
17.2 Machine	156			
Cleaning the Display	156			
Cleaning the Feed Dog	156			
Cleaning the Hook	157			
Lubricating the Hook	157			
Cleaning the thread catcher	159			
18 Errors and Faults	160			
18.1 Error messages	160			
18.2 Troubleshooting	165			
19 Storage and Disposal	168			
19.1 Storing the Machine	168			
19.2 Dispose of the Machine	168			



IMPORTANT SAFETY INSTRUCTIONS

Please be aware of the following basic safety instructions when using your machine. Before using this machine, read instruction manual carefully.

DANGER

To protect against electric shock, the following instructions must be observed.

- Never leave the machine unattended when it is connected to the power supply.
- Immediately after use and before cleaning, switch off the machine and disconnect the power cable from the outlet.

In order to protect against injury, the following instructions must be adhered to.

- Do not look directly into the LED lamp with optical instruments (e. g. magnifying glass).
- If the LED lamp is damaged or defective, have the LED lamp checked or repaired at your local authorized BERNINA dealer.
- Switch off the machine before working in the needle area.
- Before starting the machine, close all covers.

WARNING

To reduce the risk of burns, fire, electric shock or injury to persons, the following instructions must be observed.

General Facts

- This machine may only be used for the purpose described in this instruction manual.

Working Environment

- Do not use the machine outdoors.

- Only use the machine in dry rooms.
- Do not use the machine in a humid area.
- Do not use the machine in rooms where aerosol products (sprays) are being used.
- Do not use the machine in rooms where oxygen is dispensed.

Technical Condition

- Never use the machine when it is damp.
- Do not use the machine if it is not working properly.
- Do not use the machine if a cable or the plug is damaged.
- Do not use the machine if it has been dropped, damaged or has fallen into water.
- If the machine is damaged or does not work properly, have the machine checked or repaired by your local authorized BERNINA dealer.
- Keep all ventilation openings of the machine and the foot control free of lint, dust and loose cloth.
- Do not use the machine if the ventilation openings are blocked.

Accessories and Supplies

- Only use the accessories recommended by the manufacturer.
- Always use the original BERNINA Stitch Plate.
An incorrect stitch plate can result in needle breakage.
- Use only straight needles of good quality. Bent or damaged needles can cause needle breakage.
- This machine is double-insulated (except for USA, Canada and Japan). Use only identical replacement parts. See instructions for Servicing of double-insulated products.
- To lubricate the machine, only use oil recommended by BERNINA.



Safety Instructions

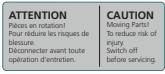
- While operating the machine, all protective inserts must be in place and all covers must be closed.

Appropriate Use

- The machine may be used, cleaned and maintained by children older than eight or by people with reduced physical, sensory or mental capabilities or if there is a lack of experience and knowledge as long as they have been given instructions.
- Furthermore, these persons must be supervised while working with the machine, and/or they must know the safe operation of the machine and be aware of the resulting hazards.
- Children are not allowed to play with the system.
- Special care should be taken when the machine is operated by or in the presence of children.
- Only use the machine with the supplied power cable.
- USA and Canada only: Do not connect power plug NEMA 1-15 to circuits exceeding 150 volt-to-ground.
- Only use this machine with the supplied foot control of type LV-1.
- Do not insert any objects into the openings of the machine.
- Do not place any objects on the foot control.
- While sewing, guide the fabric gently. Pulling and pushing the fabric can cause needle breakage.
- Keep fingers away from all moving parts.
- Special care is required in the needle area.
- For activities in the needle area - such as threading the needle, changing the needle, threading the looper or changing the presser foot - switch off the machine.
- To switch off, set the power switch to «0».

- When protective covers are removed, when the machine is oiled or when other cleaning and maintenance operations mentioned in this instruction manual are carried out, switch off the machine and disconnect the power plug from the outlet.
- Pull the plug out of the outlet by pulling on the plug. Do not pull on the cable.

Safety Signs on the Machine

Safety signs	Purpose
	<p>Caution; moving parts.</p> <p>To reduce the risk of injury, switch off the machine before maintenance work.</p>



Important Information

Availability of the Instruction Manual

The instruction manual is supplied with the machine.



- Keep the instruction manual safe at a suitable place near the machine to have it at hand in case that you need to look up something.
- If you pass the machine to a third party, always include the instruction manual.
- The latest version of the instruction manual can be downloaded at www.bernina.com

Proper Use

Your BERNINA machine is conceived and designed for private household use. It is intended for sewing fabrics and other materials as described in this instruction manual. Any other use is not considered proper. BERNINA assumes no liability for consequences resulting from improper use.


Equipment and Scope of Delivery

Example images are used in these instructions for the purposes of illustration. The machines shown in the images and the accessories shown therefore do not always match the actual items included with your machine. The supplied accessory can vary depending on the country of delivery. You can acquire any accessories mentioned or shown that are not included in the scope of delivery as optional accessories from a specialist BERNINA dealer. Further accessories can be found at www.bernina.com.

For technical reasons and in order to improve the product, changes may be made to the equipment of the machine and the scope of delivery at any time and without prior notice.

Servicing of Double-insulated Products

In a double-insulated product two systems of insulation are provided instead of grounding. No grounding means is provided on a double-insulated product nor should a means for grounded be added to the product. Servicing a double-insulated product requires extreme care and knowledge of the system and should only be done by qualified service personnel. Replacement parts for a double-insulated product must be identical to the original parts in the product. A double insulated product is marked with the words: «Double-Insulation» or «double-insulated».

 The symbol may also be marked on the product.

Environmental Protection

BERNINA International AG is committed to environmental protection. We strive to minimize the environmental impact of our products by continuously improving product design and our technology of manufacturing.



The machine is labeled with the symbol of the crossed-out wastebin. This means that the machine should not be disposed of in household waste when it is no longer needed. Improper disposal can result in dangerous substances getting into the groundwater and thus into our food chain, damaging our health.

The machine must be returned free of charge to a nearby collection point for waste electrical and electronic equipment or to a collection point for the reuse of the machine. Information on the collection points can be obtained from your local administration. When purchasing a new machine, the dealer is obliged to take back the old machine free of charge and dispose of it properly.

If the machine contains personal data, you are responsible for deleting the data yourself before returning the machine.

Explanation of Symbols

 DANGER

Designates a danger with a high risk which can lead to serious injuries or even death unless it is avoided.

 WARNING

Designates a medium-risk hazard which can lead to serious injuries if not avoided.

 CAUTION

Designates a low-risk hazard which can lead to minor or moderate injuries if not avoided.

NOTICE

Designates a hazard which can lead to material damage if not avoided.



Tips from BERNINA **quilt experts** can be found next to this symbol.



1 My BERNINA

1.1 Introduction

The purposes of your BERNINA 770 QE PLUS are sewing, embroidering and quilting. Delicate silk or satin fabrics as well as heavy-weight linen, fleece and denim can be sewn without any problems with this machine. Numerous practical as well as decorative stitches, buttonholes and embroidery motifs are at your disposal.

Additional to this instruction manual, three Help Programs are provided which will give you useful advice and support at any time how to operate your BERNINA 770 QE PLUS.

The **Tutorial** gives information and explanations about various aspects of sewing and embroidering as well as the different stitches.

The **Creative Consultant** provides decision support for sewing projects. After entering the choice of fabric and the intended sewing project, suggestions concerning the suitable needle or the appropriate presser foot are displayed.

The **Help Program** provides information about individual stitch patterns, functions and operations in the user interface.

Further information



In addition to this instruction manual for your BERNINA 770 QE PLUS, further informative print media are enclosed.

The current version of your manual as well as many other information about the machine and the accessories can be found on our website <https://www.bernina.com>

1.2 BERNINA Quality Control

All BERNINA machines are assembled with utmost care and are subjected to an extensive functionality test. The integrated stitch counter therefore indicates that the machine has already sewn stitches, which were performed exclusively for test purposes and quality control. The subsequent thorough cleaning does not exclude the possibility that thread remnants may still be found in the machine.

1.3 Welcome to the World of BERNINA

Made to create, this is the slogan of BERNINA. Not only with our machines do we support you in the implementation of your ideas. In addition to the offers listed below, we offer you lots of suggestions and instructions for your future projects as well as the opportunity to exchange ideas with other sewing, quilting and embroidery enthusiasts. We wish you lots of pleasure.

BERNINA YouTube channel



On YouTube we offer a wide range of how-to videos and support concerning the most important functions of our machines. You can also find detailed explanations many presser feet, meaning that your projects will be a complete success.

www.youtube.com/BerninaInternational

Available in English and German.

“inspiration” - the creative sewing magazine and online store with cutting patterns



Are you looking for ideas, sewing patterns and instructions for great sewing projects? In this case, the BERNINA magazine «inspiration» is exactly what you need. Three times a year, inspiration offers fantastic sewing and embroidery ideas. From seasonal fashion trends to trendy accessories and practical tips to original decorations for your home or cute sewing ideas for children.

The magazine is available in English, German, Dutch, and French.



In our online shop you can purchase "inspiration" as an e-magazine or as a print version, either as individual issues or as a subscription. Furthermore, there are many individual downloadable cutting patterns to discover! Why not take a look at inspiration.bernina.com and follow us on Instagram ([inspiration.sewing.magazin](https://www.instagram.com/inspiration.sewing.magazin)).

BERNINA Blog



Subtle instructions, free cutting patterns and embroidery designs as well as many new ideas: All this you can find in the weekly blog of BERNINA. Our experts give useful tips and explain step by step how you can achieve the desired result. In the community you can upload your own projects and exchange experiences and ideas with other sewing and embroidering enthusiasts.

www.bernina.com/blog

Available in English, German, Dutch and French.

BERNINA Social Media



Follow on social networks to learn more about events, thrilling projects as well as tips and tricks all about sewing, quilting and embroidering. We will keep you informed and we are looking forward to presenting you the one or the other highlight from the world of BERNINA.

www.bernina.com/social-media

BERNINA App



Download the BERNINA App from the App Store to your smartphone and enjoy direct access to all product information. The accessory organizer gives you an overview of your accessories and those you still would like to have. Furthermore, you have direct access to the customer portal, the blog and the "inspiration" online store, and you can always find an authorized specialist dealer near you. The app is available in the Apple App Store and the Google Play Store. You will find direct links at: www.bernina.com/app



1.4 Overview Machine

Overview front controls



- | | | | |
|---|------------------------|----|------------------------------|
| 1 | «Quick Reverse» | 7 | «Pattern Begin» |
| 2 | «Thread Cutter» | 8 | «Needle position Up/Down» |
| 3 | «Presser Foot Up/Down» | 9 | «Upper Multi-function Knob» |
| 4 | «Start/Stop» | 10 | «Lower Multi-function Knob» |
| 5 | «Pattern End» | 11 | «Needle Position Right/Left» |
| 6 | «Securing Stitches» | | |

Overview front



- | | | | |
|---|---|----|---------------------------------|
| 1 | Connection for Embroidery Module | 7 | Speed Control |
| 2 | Bobbin Cover | 8 | Thread Take-up Lever Cover |
| 3 | Connection for Accessory (Optional Accessory) | 9 | Thread Take-up Lever |
| 4 | Presser Foot | 10 | Fixing Screw |
| 5 | Needle Threader | 11 | Connection for Slide-on Table |
| 6 | Sewing Light | 12 | Connection for Free Hand System |

Overview sideways



- | | | | |
|---|---------------------------------------|----|-------------------------------------|
| 1 | Connection for Foot Control | 7 | Power Switch |
| 2 | PC-connection | 8 | Connection for Power Cable |
| 3 | Spool Pin | 9 | Magnetic Holder for Touchscreen Pen |
| 4 | Bobbin Unit Switch with Thread Cutter | 10 | Air Vents |
| 5 | Swiveling Spool Pin | 11 | USB Port |
| 6 | Handwheel | 12 | Feed Dog Up/Down |

Overview - Back panel



- | | | | |
|---|-------------------------------|----|--------------------------|
| 1 | Connection for Slide-on Table | 8 | Carry Handle |
| 2 | Connection for Darning Hoop | 9 | Bobbin Winder Pretension |
| 3 | BSR connection | 10 | Thread Guide |
| 4 | Connection for accessory | 11 | BDF BERNINA Dual Feed |
| 5 | Air Vents | 12 | Thread Cutter |
| 6 | Thread Guide | 13 | Feed Dog |
| 7 | Bobbin Winding Unit | 14 | Stitch Plate |

1.5 Supplied Accessories



You will find further information and application tips on the supplied and optional accessories at: <https://www.bernina.com/770qe-plus#!accessories>

Overview Accessories Machine





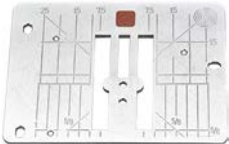























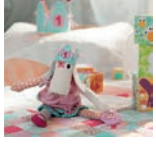
Illustration	Name	Purpose
	Dust Cover	To protect the machine from dust and contamination.
	BERNINA Accessories Box	To store the supplied accessories as well as optional accessories.
	Free Hand System (FHS)	To raise and lower the presser foot.
	Slide-On Table	To increase the sewing surface.
	Straight and CutWork Stitch Plate	To sew straight stitches and for CutWork.
	Spool Cap	To support the regular unwinding of the thread from the spool.
	Bobbin for B9 Hook Set of 5	To wind the bobbin thread.
	Foam Pad 2 pieces	The foam pad prevents the thread from slipping, tangling or breaking on the spool pin.
	Touchscreen Pen	For precise operation of the touch screen.

Illustration	Name	Purpose
	Seam Ripper	To undo seams and to cut buttonholes open.
	Height Compensating Tool	To level an angled position of the presser foot sole when sliding over thick seams.
	Needle Assortment	For any common applications.
	Right Seam Guide	To align regular seam distances.
	Screwdriver Torx, gray	To change the needle.
	Screwdriver red (slot)	To loosen and tighten slotted screws.
	Angular Torx Wrench Torx	To open the headframe.
	Brush/Needle Inserter	To clean the feed dog and the looper area.
	Sewing Machine Oil	To oil the machine.
	Power Cable	To connect the machine with the power supply system.
	Foot Control	To start and stop the machine. To control the sewing speed.

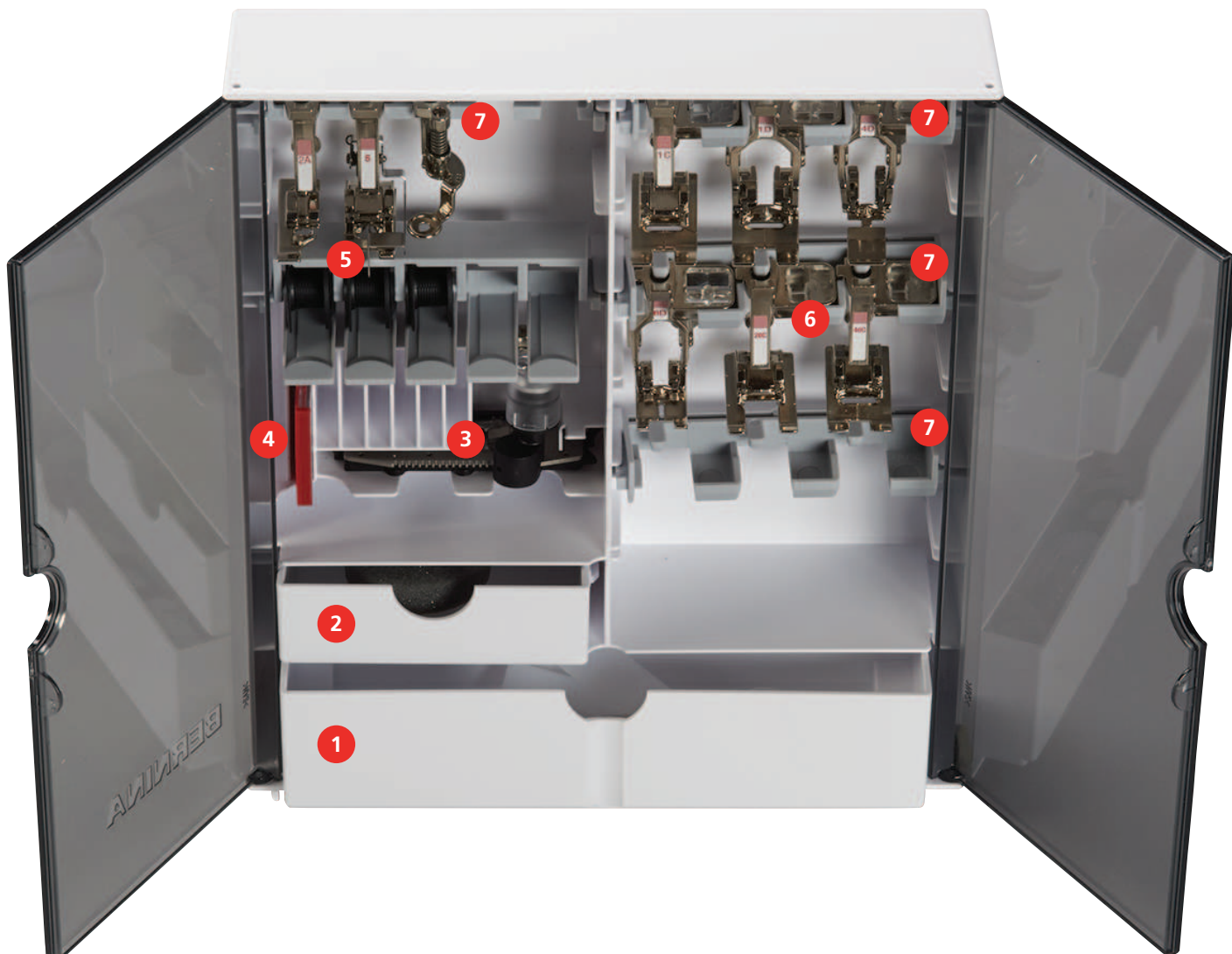
Overview Presser Feet

Supplied Standard Presser Feet

Illustration	Number	Name	Purpose	Example
	#1C	Reverse Pattern Foot	For sewing different practical and decorative stitches. To sew forward and in reverse.	
	#1D	Reverse Pattern Foot	For sewing different practical and decorative stitches. To sew forward and in reverse.	
	#3A	Buttonhole Foot with Slide	To sew buttonholes automatically.	
	#4D	Zipper Foot	For sewing in zippers.	
	#20C	Open Embroidery Foot	For sewing applications and decorative patterns.	
	#42	BERNINA Stitch Regulator (BSR)	Free-motion quilting with regular stitch length.	
	#97D	Patchwork Foot	For patchwork and other exact work, if working with BERNINA Dual Feed.	

Accessory box

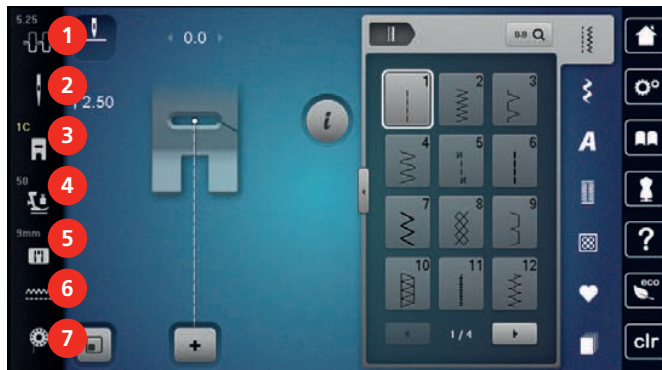
In the accessory box, accessories can be neatly stored in compartments and matching holders.



- | | | | |
|---|----------------------------|---|---|
| 1 | Big drawer | 5 | Spool Pin |
| 2 | Small drawer | 6 | Presser Feet |
| 3 | Buttonhole foot with slide | 7 | Presser Foot Holders for 5.5 mm and 9.0 mm feet |
| 4 | Selection of needles | | |

1.6 Overview User Interface

Overview functions/visual information



- | | | | |
|---|---|---|--------------------------|
| 1 | «Upper Thread Tension» | 5 | «Stitch Plate Selection» |
| 2 | «Needle Selection» | 6 | «Feed Dog Indicator» |
| 3 | «Presser Foot Indicator/Presser Foot Selection» | 7 | «Bobbin Thread» |
| 4 | «Foot Pressure» | | |

Overview System settings



- | | | | |
|---|-----------------------|---|------------------|
| 1 | «Home» | 5 | «Help» |
| 2 | «Setup Program» | 6 | «eco Mode» |
| 3 | «Tutorial» | 7 | «Clear Settings» |
| 4 | «Creative Consultant» | | |

Overview selection menu sewing



- | | | | |
|---|-----------------------|---|-------------------|
| 1 | «Practical Stitches» | 5 | «Quilt Stitches» |
| 2 | «Decorative Stitches» | 6 | «Personal Memory» |
| 3 | «Alphabets» | 7 | «History» |
| 4 | «Buttonholes» | | |

Software Operation







The touch-sensitive display can be operated with the finger or stylus.

Tap: Short tap of an element..





Swipe: Tap an element and swipe quickly on the display.

Draw: Tap the display and slowly move in one direction, eg. for scrolling up and down.

Navigation

Illustration	Name	Purpose
	«Home»	Show Home screen.
	Navigation Path	Show a previous menu level.
	«Close»	Close the window.
	More	Show more features or information.
	Continue	Scroll to next display.
	Back	Scroll to previous display.

Activate/Deactivate Functions

Illustration	Element	Status
	Switch	Function is activated.
		Function is deactivated.
	Icon	Function is deactivated.
		Function is activated.

Adjust Values


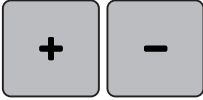
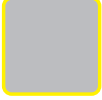


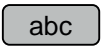

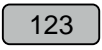
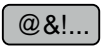


Illustration	Name	Purpose
	Slider Control	Set the value with the slider control. Reset the value to the default value by tapping the small bullet.

Illustration	Name	Purpose
	Field «Plus» / «Minus»	«Plus» increase, «Minus» reduce the value.
	Yellow Frame	Indication that the set value differs from the default value. Reset the value to the default value by tapping.

Enter Text and Numbers

To enter numerical values or text, a corresponding keyboard is shown.



Illustration	Name	Purpose
	Entry Field	Display of the entry. Delete all characters entered with a single tap.
	«Deleting»	Delete the last character.
	«Lower Case Characters»	Show the available letters in lower case letters.
	«Upper Case Characters»	Show the available letters in upper case letters.
	«Numbers and Mathematical Characters»	Show the available numbers and mathematical characters.
	«Special Characters»	Show the available special characters.
	«Confirm»	Confirm the entry and leave the submenu.
	«Cancel»	Cancel the entry and the view closes.

1.7 Needle, Thread, Fabric

Needles will wear down over time. Therefore, the needle should be replaced regularly. Only a perfect point results in a good stitching result. In general, the thinner the fabric, the finer the needle. The illustrated needles are either standard or optional accessory, depending on the machine.

- Needle sizes 70, 75: for light-weight fabrics.
- Needle sizes 80, 90: for medium fabrics.
- Needle sizes 100, 110 and 120: for heavy fabrics.

Overview Needles

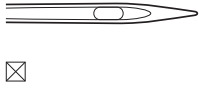
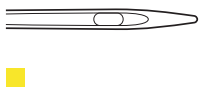
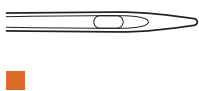
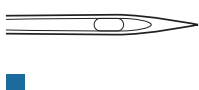
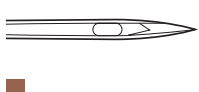
Illustration	Needle Name	Needle Description	Purpose
	Universal Needle 130/705 H 60/8 – 120/19	With a slightly rounded point.	For woven fabrics (light, medium, heavy-weight), knitwear, leather, plastic, jeans/denim. For natural and synthetic fabrics. For general sewing, sewing on buttons and buttonholes, zippers, hems and topstitching, decorative sewing, embroidery, patchwork, quilting.
	Stretch Needle 130/705 H-S 75/11 – 90/14	With a medium ball point.	For knitwear (jersey, tricot, knit and stretch material). For general sewing, sewing on buttons and buttonholes, zippers, hems and topstitching, decorative sewing, embroidery.
	Jersey/ Embroidery Needle 130/705 H SUK 80/12	With a medium ball point.	For woven fabrics (light, medium, heavy-weight), knitwear, plastic. For general sewing, sewing on buttons and buttonholes, zippers, hems and topstitching, decorative sewing, embroidery.
	Jeans Needle 130/705 H-J 80/12 – 110/18	With slim, particularly acute point.	Woven fabrics (light, medium, heavy-weight), leather, jeans/denim. For general sewing, sewing on buttons and buttonholes, zippers, hems and topstitching, decorative sewing, embroidery, patchwork, quilting.
	Leather Needle 130/705 H LR 90/14, 100/16	With a cutting point (LR = special point to sew leather).	For leather, imitation leather and other similar materials. For zippers, hems and topstitching, materials that tend to stick.

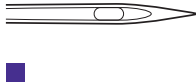
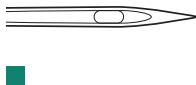
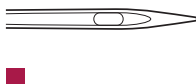
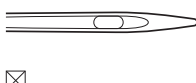
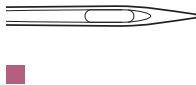
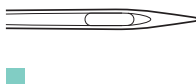



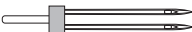



Illustration	Needle Name	Needle Description	Purpose
	Microtex Needle 130/705 H-M 60/8 – 110/18	With a particularly pointed and slender tip.	For woven fabrics (light, medium, heavy), artificial materials and materials that are difficult to work with. For silk, microfibre fabrics, foils, coated and hard-sliding materials. For sewing in general, sewing on buttons and buttonholes, zips, hems and topstitching and decorative sewing. For ultra straight stitches when topstitching edges.
	Quilting Needle 130/705 H-Q 75/11 – 90/14	With a very slim, slightly rounded point.	For woven fabrics (light, medium and heavy-weight). Decorative sewing, patchwork, quilting. For stitching/topstitching tasks, such as quilting and patchwork.
	Embroidery Needle 130/705 H-E 75/11 – 90/14	With a light ball point and a particularly wide eye and wide groove.	For woven fabrics (light, medium, heavy-weight), knitwear. For voluminous and woolen threads. For general sewing, sewing on buttons and buttonholes, zippers, hems and topstitching, decorative sewing, embroidery.
	Fine Fabrics Needle 130/705 H SES 70/10 – 90/14	With a light ball point.	For fine, delicate materials, such as velvet. For general sewing, sewing on buttons and buttonholes, zippers, hems and topstitching, decorative sewing, embroidery, patchwork, quilting.
	Metafil Needle 130/705 H METAFIL 80/12	With medium ball point and long eye (2 mm).	For woven fabrics (light, medium, heavy-weight), knitwear. For sewing with special effects and fancy threads, especially metallic threads. For embroidery with metallic thread. For hems and topstitching, decorative sewing and embroidery.
	Topstitch Needle 130/705 H-N 80/12 – 100/16	With medium ball point and long eye (2 mm).	For woven fabrics (light, medium and heavy-weight). For hems and topstitching, decorative sewing and embroidery. For decorative and quilting work with several sewing threads and also for embroidery.

Illustration	Needle Name	Needle Description	Purpose
	Felting Needle PUNCH	With small barbs.	For woven fabrics (light, medium, heavy-weight), jeans/denim. For felting a variety of yarns and threads into base fabrics.
 ☒	Hemstitch Needle 130/705 H WING 100/16, 120/20	With a «wing» on each side of the needle blade.	For woven fabrics (light, medium and heavy-weight). For special effects with hemstitch embroidery.
 ☒	Universal Twin Needle 130/705 H ZWI 70-100	Needle distance: 1.0/1.6/2.0/2.5/3.0/4.0/6.0/8.0	For visible hems in stretch fabrics, pintucks, decorative sewing.
 ☒	Stretch Twin Needle 130/705 H-S ZWI 75	Needle distance: 2.5/4.0	For visible hems in stretch fabrics, pintucks, decorative sewing.
 ☒	Hemstitch Twin Needle 130/705 H ZWIHO 100	Needle distance: 2.5	For special effects with hemstitch embroidery.
 ☒	Universal Triple Needle 130/705 H DRI 80	Needle distance: 3.0	For visible hems in stretch fabrics, decorative sewing.

Example for Needle Description

The 130/705 system, which is the most common for household machines, is explained by the following picture of a Jersey/Stretch needle.

	<p>130/705 H-S/70</p> <p>130 = Shank length (1)</p> <p>705 = Flat shank (2)</p> <p>H = Needle scarf (3)</p> <p>S = Needle point (here medium ball point) (4)</p> <p>70 = Needle size 0.7 mm (5)</p>
---	---

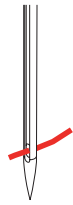
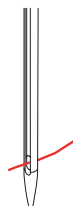

Thread Selection

For a perfect sewing result, thread and fabric quality play an important role.

We recommend purchasing quality threads to achieve good sewing results.

- Cotton threads have the advantage of being a natural fiber and therefore are especially suitable for sewing cotton fabrics.
- Mercerized cotton threads have a slight sheen that is not lost with washing.
- Polyester threads have a high tensile strength and is particularly colorfast.
- Polyester threads are more flexible and are recommended where a strong and elastic seam is required.
- Rayon threads are made of natural fibers and have a brilliant sheen.
- Rayon threads are suitable for decorative stitches and achieve a more beautiful effect.

Needle/Thread Combination

	<p>The needle/thread combination is correct, when the thread fits perfectly into the long groove and goes easily through the needle eye. The thread can be optimally sewn.</p>
	<p>The thread can break and skipped stitches can occur when there is too much clearance in the long groove and the needle eye.</p>
	<p>The thread can break and get stuck when the thread scrapes against the edge of the long groove not fit well into the needle eye optimally.</p>

2 Sewing Preparation

2.1 Before Using the Machine for the First Time



BERNINA recommends lubricating the hook before using the machine for the first time or after a longer period of non-use. (see page 155)

By oiling the hook, the occurrence of unwanted noises in the hook area can be avoided.

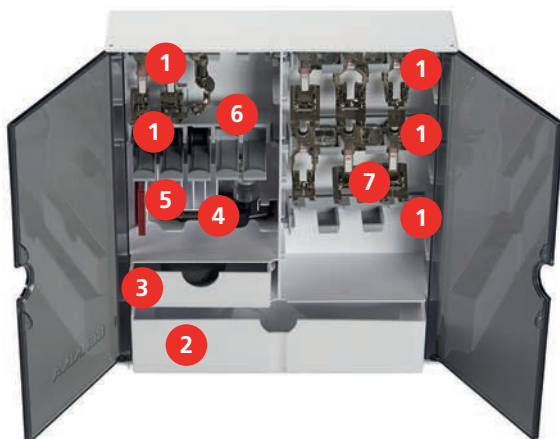
2.2 Accessories Box

Accessory box free standing

> On the back of the box, pull both extensions out until they click into place.



Storing accessory



- > Insert the holders (1) for bobbins, presser feet and needles into the accessory box.
- > Store the presser feet in the holders (7) (5.5 mm or 9.0 mm).
- > Store the small parts, e.g. thread discs etc., in the drawers (2) and (3).
- > Buttonhole Foot with Slide #3A in compartment (4).
- > Store the provided needle package in the special compartment (5).

NOTICE**Scratched Sensor Surfaces of the Bobbin**

Malfunction of the lower thread indicator. If the sensor surfaces of the bobbins are scratched or dirty, the bobbin thread indicator will no longer detect the low thread level.

> Always position the bobbins in the bobbin holder with the silver sensor surface to the right.

> Position the bobbins in the bobbin holder (6) with the silver sensor surface to the right.

> To remove a bobbin, press the compartment holder down.

2.3 Connection and Switching On**Connecting the Foot Control**

The cable of the foot control is rolled up on its underside.

> Unroll the cable of the foot control to the desired length and fix it in the cable holders of the foot control.



> Insert the plug of the cable into the foot control socket of the machine.



> Place the foot control under the table.

> If the cable is too long, roll up the excess length and fix it in the cable holders of the foot control.

Connecting the Machine

To ensure safe operation of the machine, only the supplied mains cable may be used. The supplied power cable is designed for the voltage range applicable in the country of use. If the machine is to be used in a country other than the country of origin, the power cable suitable for that country must be obtained from the Authorized BERNINA dealer.

The power cable for the USA and Canada has a polarized power plug (one contact is wider than the other). To reduce the risk of an electric shock, the plug can only be inserted into the socket in one way. If the power plug does not fit in the socket, reverse then insert the power plug. If the reversed power plug still does not fit, an electrician must install an appropriate socket. Do not modify the power plug in any way.

- > Insert the device connector of the power cable into the machine's power cable connection.



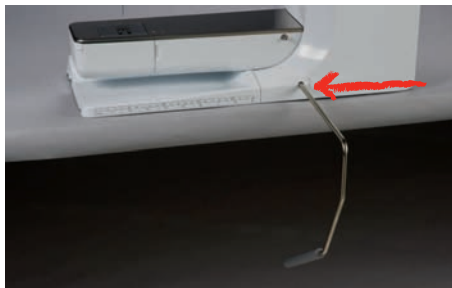
- > Insert the power plug of the power cable into the socket.

Attaching the Knee Lifter of the Free Hand System



The lateral position of the lever can be adjusted by your local BERNINA Dealer required.

- > Insert the knee lifter into the opening at the front side of the machine.
- > Adjust the sitting height so that the knee lifter can be operated with the knee.



Fixing the Touch Screen Pen

- > Store the touchscreen pen at the magnet holder.



Switching the Machine On

- > Set the power switch to «I».



2.4 Foot Control

Regulating the Speed via the Foot Control

Via the foot control the speed can be adjusted infinitely variable.

- > Press the foot control down carefully to start the machine.
- > To sew faster, press the foot control harder.
- > Release the foot control to stop the machine.



Activate/Deactivate Additional Function

The Foot Control can be programmed with a second function that can be activated and deactivated by a Back-kick. On delivery, the Back-kick is programmed with the function «Needle Up/Down».

- > To raise or lower the needle, press the foot control downward with your heel.



The Back-kick function can be programmed individually. (see page 50)

2.5 Spool Pin

Swiveling Spool Pin

Installing the spool holder



With metallic or other special threads, it is recommend to use the swiveling spool pin.

The swiveling spool holder is necessary when several threads are sewn and it can also be used for bobbin winding while sewing.

- > Swivel the spool holder up as far as it will go.



Inserting foam pad and thread spool

The foam pad prevents the thread from getting hooked at the swiveling spool holder.

- > Place the foam pad on the swiveling spool holder.
- > Place the thread spool on the spool holder.



Horizontal Spool Pin

Placing the Foam Pad, the Thread Spool and the Spool Cap

Spool caps hold the thread spool in place for proper release of thread from the spool. The spool cap is only used with the horizontal spool holder.

- > Place the foam pad on the spool pin.
- > Place the thread spool on the spool pin.
- > Position the appropriate spool cap on the spool pin so that there is no space between the spool cap and the thread spool.



Using the Spool Net

The spool net holds the thread on the thread spool and prevents the thread from knotting and breaking. The spool net is only used with the horizontal spool holder.

- > Pull the spool net over the thread spool. Ensure when doing so that the spool net does not slip off the thread spool, e.g. double-insert the net over the thread spools or insert a part of the net into the thread spool at the rear.



2.6 Feed Dog

Adjusting the Feed Dog

- > To lower the feed dog, push the button «Feed Dog Up/Down».



- > To raise the feed dog, push the button «Feed Dog Up/Down» again.

2.7 Slide-on Table

Using the Slide-on Table

The Slide-on Freearm Extension Table, attached to the freearm, enables the available sewing area to be extended.

- > Raise the needle.
- > Raise the presser foot.
- > Switch off the machine.
- > Push the Slide-on Freearm Extension Table from the left to the right over the freearm until it engages.



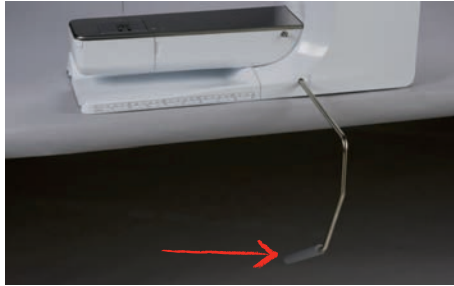
- > To remove the Slide-on Freearm Extension Table, press the button at the table down and pull the slide-on table over the free arm to the left.



2.8 Presser Foot

Adjusting the Presser Foot Position via the Knee Lifter of the Free Hand System

- > Adjust the sitting height so that the knee lifter can be operated with the knee.
- > Push the knee lifter with the knee to the right to raise the presser foot.



- Simultaneously the feed dog is lowered and the thread tension is released.
- > Release the knee lifter slowly to lower the presser foot.

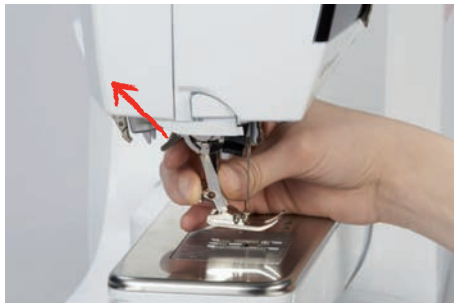
Adjusting the Presser Foot Position via the Button «Presser Foot Up/Down»



- > To raise the presser foot, push the button «Presser Foot Up/Down».
- > To lower the presser foot, push the button «Presser Foot Up/Down» again.

Changing the presser foot

- > Raise the needle.
- > Raise the presser foot.
- > Switch off the machine.
- > Push the clamping lever up.



- > Remove the presser foot.
- > Guide the new presser foot upwards over the cone.
- > Press the clamping lever down.

Selecting the Presser Foot in the User Interface

After changing the presser foot, a check can be performed to determine whether it is suitable for the selected stitch pattern. Additionally, alternative presser feet are displayed, which are available for the selected stitch pattern.

- > Switch the machine on.
- > Select the stitch pattern.
- > Tap «Presser Foot Indicator/Presser Foot Selection».





> To display all suitable presser feet for the selected stitch pattern, tap «Optional Presser Feet».



- > Select the attached presser foot.
 - When the selected presser foot is suitable, sewing can start.
 - If the selected presser foot is not suitable for the selected stitch pattern, it can still be selected but the machine is automatically prevented from starting. An error message is displayed. If an incorrect presser foot is selected, the sewing stitch is displayed in red in the sewing stitch preview.



Setting the Presser Foot Pressure



The presser foot pressure is designed to adjust the pressure of the presser foot optimally to the fabric thickness. When working with thick fabrics, it is recommended to reduce the presser foot pressure. This provides the advantage that the fabric can be moved more easily. When the presser foot pressure is set below 0, the presser foot even lifts to give more space to the thick fabric. When working with thin fabrics, it is recommended to increase the presser foot pressure. This provides the advantage that the fabric cannot be moved too easily under the presser foot.



- > Tap «Foot Pressure».
- > Adjust the presser foot pressure.

2.9 Needle and Stitch Plate

Changing the needle

- > Raise the needle.
- > Switch off the machine.
- > Remove the presser foot.



- > Loosen the Fixing Screw of the needle using the Screwdriver (Torx, gray).



- > Pull the needle down.
- > Hold the new needle with the flat side to the back.
- > Insert the needle as far as it will go.
- > Tighten the Fixing Screw with the Screwdriver.

Selecting the needle in the User Interface

After changing the needle, you can check whether this can be used with the selected stitch plate.



- > Tap «Needle Selection».
- > Select the fitted needle.



- When the selected needle matches the selected presser foot, sewing can be started. If the selected needle does not match the selected presser foot, there will be an error message when starting the machine and the machine will not sew.

Selecting needle type and needle size

Convenient memory function: To prevent a loss of information, the needle type and the needle size can be saved additionally on the machine. The saved needle type and the saved needle size can be checked at any time.



- > Tap «Needle Selection».



- > Tap «Needle Information».
- > Select the needle type (1) of the fitted needle.

- > Select the needle type (2) of the fitted needle.



Adjusting the Needle Position Up/Down



- > To lower the needle, push the button «Needle position Up/Down».
- > To raise the needle, push the button «Needle position Up/Down» again.

Adjusting the Needle Position Left/Right

There is a total of 11 needle positions. The needle position is indicated by the needle position number in the display.

- > To position the needle position to the left, push the button «Needle Position Left» (1).
- > To position the needle position to the right, push the button «Needle Position Right» (2).



Needle Stop Up/Down (Permanent)



- > To set the needle stop position permanently, tap «Needle Stop Up/Down».
 - The machine stops with needle position down as soon as the foot control is released or the button «Start/Stop» has been pushed.
- > Tap «Needle Stop Up/Down» again.
 - The machine stops with needle position up as soon as the foot control is released or the button «Start/Stop» has been pushed.

Changing the Stitch Plate

The stitch plate is marked with vertical, horizontal and diagonal lines in millimeters (mm) and inches (inch). These markings are helpful for sewing or precise top-stitching.

Prerequisite:

- The feed dog is lowered.
 - The machine is switched off.
 - The needle and presser foot are removed.
- > At the marking on the upper right corner of the stitch plate, push the stitch plate downwards until it tips.



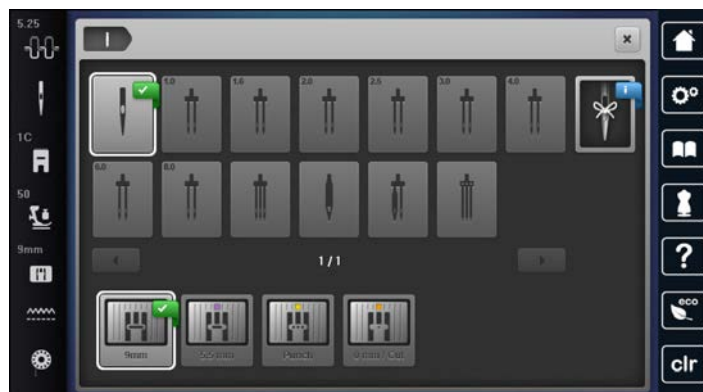
- > Remove the stitch plate.
- > Place the openings of the new stitch plate above the corresponding guide pins and press down until it clicks into place.

Selecting the stitch plate in the User Interface

After changing the stitch plate, you can check whether this can be used with the selected needle.



- > Tap «Stitch Plate Selection».
- > Select the previously fitted stitch plate.



- If the selected stitch plate is suitable to be used in combination with the needle, sewing can begin.
- If the selected stitch plate is not suitable to be used in combination with the needle, an error message is displayed and starting the machine is automatically prevented.

2.10 Threading

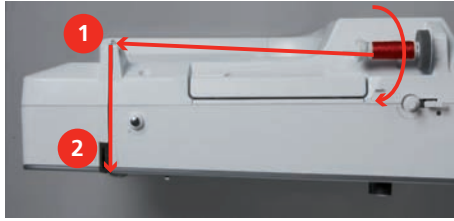
Threading the upper thread

Prerequisite:

- The needle and the presser foot are raised.
 - The machine is switched off.
- > Place the foam pad on the spool pin.
- > Place the thread spool on the spool pin so that the thread unwinds clockwise.
- > Attach the appropriate spool cap.
- > Guide the thread in direction of the arrow through the rear thread guide (1) and hold the thread with the hands so that it is taut and can be inserted into the thread tension.



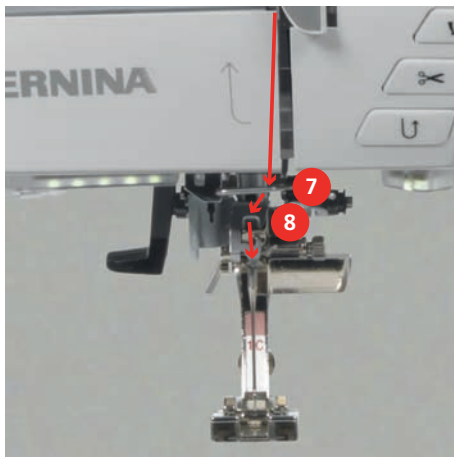
- > Guide the thread in direction of the arrow through the thread tension (2).



- > Guide the thread downwards (3) around the thread take-up lever cover (4).
- > Guide the thread upwards and insert into the thread take-up lever (5).
- > Guide the thread downwards again (6).



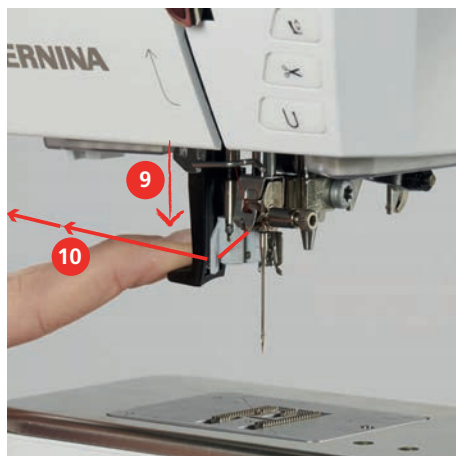
- > Guide the thread through the guides (7/8) above the presser foot.



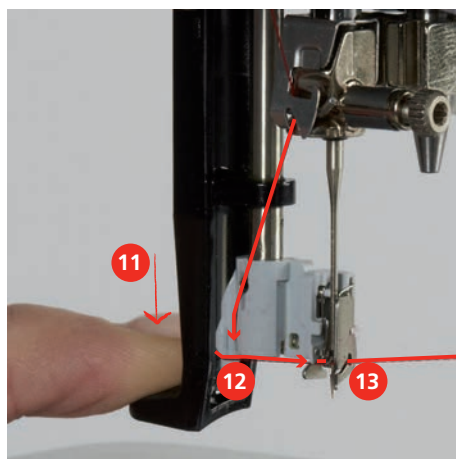
- > Switch the machine on.



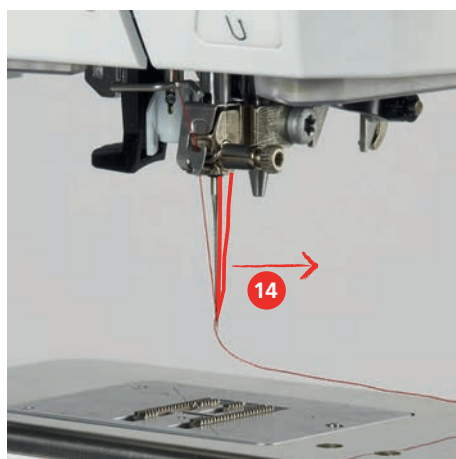
- > Press the semi-automatic threader lever (9) slightly down, keep it pressed and pull the thread to the left beneath the gray threader finger/hook (10).



- > Guide the thread around the gray threader hook from the left to the right (12).
- > Press the threader lever down as far as it will go (11) and then pull the thread from the left to the right (12) through the threader slot (13) until it hooks into the small wire hook.



- > Release the lever and the thread simultaneously to thread.
- > Pull the thread loop (14) to the back.



- > Pull the thread beneath the presser foot from back to front over the thread cutter (15) and cut.



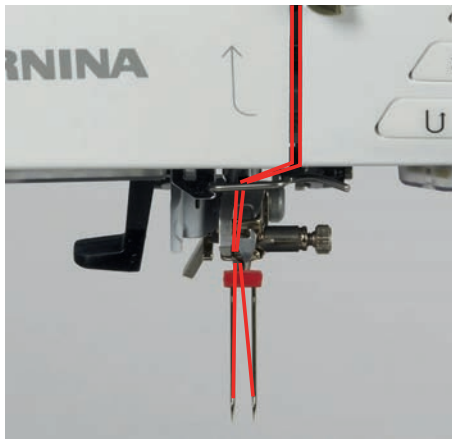
Threading the Twin Needle

Prerequisite:

- The twin needle is inserted.
- > Guide the first thread in direction of the arrow on the right side of the tension disc (1).
- > Guide the second thread in direction of the arrow on the left side of the tension disc (1).



- > Guide the first and the second thread to the thread guide above the needle.
- > Thread the first thread manually into the right needle.
- > Thread the second thread manually into the left needle.

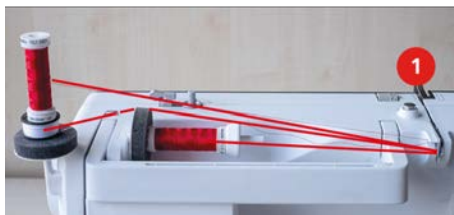


Threading the triple needle

Prerequisite:

- The triple needle is inserted.
- > Place the foam pad, the thread spool and the appropriate spool cap on the horizontal spool pin.
- > Place the foam pad on the vertical spool pin.
- > Attach the filled bobbin on the vertical spool pin so that the silvery sensor surface is down.
- > Attach the thread spool in the opposite direction to the bobbin.

- > Thread the 3 threads up to the upper thread guide.



- > Guide 2 threads (vertical spool pin) past the thread tension disc (1) on the left and up to the thread guide above the needle.
- > Guide 1 thread (horizontal spool pin) past the thread tension disc (1) on the right and up to the thread guide above the needle.
- > Thread 1 thread of the vertical thread spool pin into the left and right needle by hand.
- > Thread the thread of the horizontal spool pin into the center needle manually.

Winding the bobbin thread



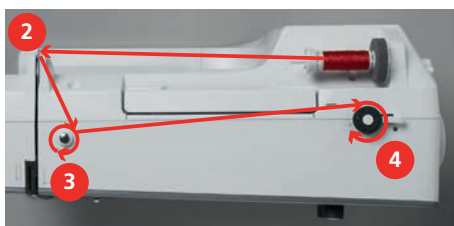
The bobbin thread can be wound while embroidering if the swiveling spool holder is used for winding.

Prerequisite:

- The foam pad, the thread spool and the appropriate spool disc are fitted.
- > Place the empty bobbin on the Winding Unit (1) so that the silvery sensor surface is down.



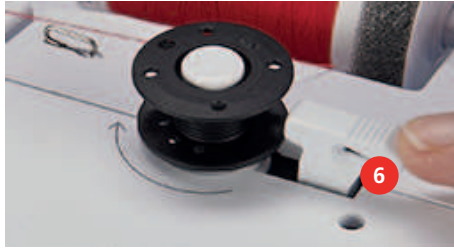
- > Guide the thread to the left into the rear thread guide (2).
- > Guide the thread around the bobbin winder pretension clockwise (3).
- > Wind the thread clockwise 2 – 3 times around the empty bobbin (4).



- > Pull the excess thread over the thread cutter at the engaging lever (5) and cut.



- > Push the engaging lever (6) towards the bobbin.

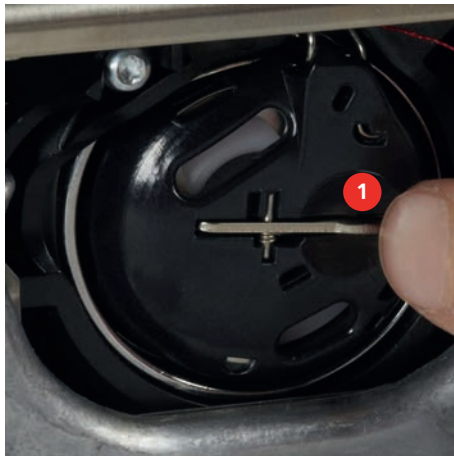


- The machine winds and the display to wind the bobbin appears.
- > Set winding speed.
- > To stop the winding process, the engaging lever must be pushed to the right.
- > Push the engaging lever towards the bobbin again to continue the winding process.
 - As soon as the bobbin is full, the machine stops the winding process automatically.
- > Remove the bobbin and cut the thread using the thread cutter at the engaging lever.

Threading the Bobbin Thread

Prerequisite:

- The needle is raised.
- The machine is switched off and the bobbin cover is opened.
- > Press the bobbin case release at the bobbin case (1).



- > Remove the bobbin case.
- > Remove the bobbin from the bobbin case.
- > Insert the new bobbin so that the silvery sensor surface is facing the back of the bobbin case.



- > Pull the thread into the slot (2) from the left.



- > Pull the thread to the right under the spring (3), then pass it below the two thread guides (4) and pull it upwards.



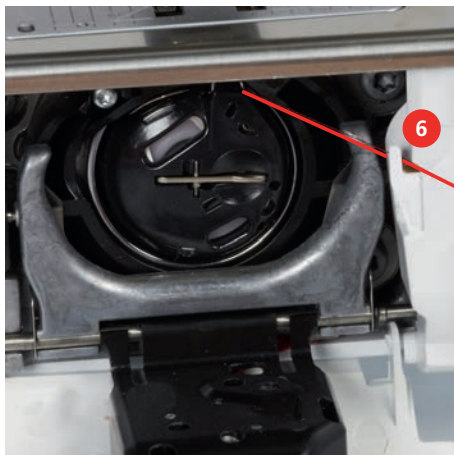
- > To insert the bobbin case into the machine, hold it so that the thread guide (5) points upwards.



- > Insert the bobbin case.
- > Press onto the center of the bobbin case until it engages.



- > Pull the thread through the thread cutter (6) and cut.



- > Close the looper cover.

Indicating Fill Level of Bobbin Thread

When the fill level of the bobbin thread is low, an animation appears in the icon «Bobbin Thread» to indicate that the bobbin thread is about to run out.



- > To thread the bobbin thread according to the animation, tap, «Bobbin Thread».

3 Setup Program

3.1 Sewing Settings

Adjusting the Upper Thread Tension

Changes to the upper thread tension in the Setup Program affect all of the stitch patterns. The setting in the setup is retained after the machine is switched off.



> Tap «Setup Program».



> Tap «Sewing Settings».



> Tap «Adjusting the Upper Thread Tension».
> Adjust the upper thread tension.

Adjusting the Maximum Sewing Speed

The maximum speed can be reduced by this function.



> Tap «Setup Program».



> Tap «Sewing Settings».



> Tap «Maximum Sewing Speed».
> Set the maximum sewing speed.

Programming Securing Stitches

If the function is switched on, 4 securing stitches are automatically sewn at the start of the pattern after the thread cut.



> Tap «Setup Program».



> Tap «Sewing Settings».



> Switch «Securing Stitches at the Start of the Pattern» on or off.

Adjusting the hovering height of the presser foot

The hovering height of the presser foot can be adjusted according to the fabric thickness from 0 to maximal 7 mm.

Set hovering height = fabric thickness + required clearance between the fabric and the presser foot in the floating position.



> Tap «Setup Program».



> Tap «Sewing Settings».



> Tap «Programming Buttons and Icons».



> Tap «Programming the Hovering Height of the Presser Foot».
> Adjust the distance between the fabric and the presser foot.

Programming the button «Pattern end»

The presser foot can be positioned, the thread cut and the automatic securing can be programmed.



> Tap «Setup Program».



> Tap «Sewing Settings».



> Tap «Programming Buttons and Icons».



> Tap «Programming the Button Pattern End».



> To activate the automatic securing, tap «Securing Stitches».
> To deactivate automatic securing, tap «Securing Stitches» again.



> To program subsequent securing stitches, tap «Securing Stitches in Close Succession».
> To program the number of subsequent securing stitches, tap «Plus» or «Minus».



> To program 4 securing stitches in place, tap «Securing Stitches in Place».



> To deactivate the automatic thread cut after securing, tap «Automatic Thread Cutter».
> To activate the automatic thread cut after securing, tap «Automatic Thread Cutter» again.



> To keep the presser foot in lowered position, tap «Raise the Presser Foot».
> To raise the presser foot after securing, tap «Raise the Presser Foot» again.

Programming the button «Thread cutter»

The automatic securing can be programmed before the thread cut takes place.



> Tap «Setup Program».



> Tap «Sewing Settings».



> Tap «Programming Buttons and Icons».



> Tap «Programming the Button Thread Cutter».



> To activate the automatic securing, tap «Securing Stitches».
> To deactivate automatic securing, tap «Securing Stitches» again.



> To program subsequent securing stitches, tap «Securing Stitches in Close Succession».
> To program the number of securing stitches, tap «Minus» or «Plus».



> To program 4 securing stitches in place, tap «Securing Stitches in Place».

Adjusting the presser foot position with needle stop down

With lowered needle, 3 different presser foot position can be selected: the presser foot lowered, the presser foot is raised to hovering position and the presser foot is raised to its maximum height.



> Tap «Setup Program».



> Tap «Sewing Settings».

Setup Program



> Tap «Programming Buttons and Icons».



> Tap «Pressure Foot Position with Needle Stop Down».



> Select the desired presser foot position.

Programming the button «Quick reverse»

It can be either chosen «Reverse Sewing» or «Backstepping».



> Tap «Setup Program».



> Tap «Sewing Settings».



> Tap «Programming Buttons and Icons».



> Tap «Programming the Button Quick Reverse».



> To set the stitch-precise reverse sewing, tap «Back Stepping».



> To set the reverse sewing, tap «Quick Reverse».

Programming the button «Securing»

The number and type of securing stitches can be programmed.



> Tap «Setup Program».



> Tap «Sewing Settings».



> Tap «Programming Buttons and Icons».



> Tap «Programming the Button Securing».



> To program subsequent securing stitches, tap «Securing Stitches in Close Succession».

> To program the number of securing stitches, tap «Minus» or «Plus».



> To program 4 securing stitches in place, tap «Securing Stitches in Place».

Programming the foot control









If «Needle Up/Down» is activated, the needle is raised or lowered with the back-kick on the foot control. Alternatively, the presser foot can be positioned, the thread can be cut and the automatic securing can be programmed.



> Tap «Setup Program».






> Tap «Sewing Settings».

-  > Tap «Programming the Foot Control».
- 
 - «Needle Up/Down» is activated in the default setting.
 - The back-kick on the foot control raises or lowers the needle.
-  > To program the Back-kick, tap «Programming the Back-kick».
- 
 - > To deactivate the automatic securing via the Back-kick, tap «Securing Stitches».
 - > To activate the automatic securing via the Back-kick, tap «Securing Stitches» again.
- 
 - > To program subsequent securing stitches, tap «Securing Stitches in Close Succession».
 - > To program the number of securing stitches, tap «Minus» or «Plus».
-  > To program 4 securing stitches in place, tap «Securing Stitches in Place».
- 
 - > To deactivate the automatic thread cut via the Back-kick, tap «Automatic Thread Cutter».
 - > To activate the automatic thread cut via the Back-kick, tap «Automatic Thread Cutter» again.
- 
 - > To keep the lowered position of the presser foot via the Back-kick, tap «Raise the Presser Foot».
 - > To keep the raised position of the presser foot via the Back-kick, tap «Raise the Presser Foot» again.

3.2 Embroidery Settings




Adjusting the Upper Thread Tension

Changes to the upper thread tension in the Setup Program affect all of the embroidery designs.

-  > Tap «Setup Program».
-  > Tap «Embroidery Settings».
- 
 - > Tap «Adjusting the Upper Thread Tension».
 - > Adjust the upper thread tension.



Adjusting the Maximum Embroidering Speed

The maximum speed can be reduced by this function.

-  > Tap «Setup Program».
-  > Tap «Embroidery Settings».
- 
 - > Tap «Maximum Embroidery Speed».
 - > Set the maximum sewing speed.

Centering or opening embroidery motifs in the original position

When opening the embroidery motifs on the machine, they are always centered in the Embroidery Hoop. If it is desired to open embroidery motifs in the original position (determined by the BERNINA Embroidery Software), the function «Centering the Embroidery Design» must be activated.

-  > Tap «Setup Program».
-  > Tap «Embroidery Settings».

Setup Program



> Tap «Centering the Embroidery Design».



> Tap the Switch.

- A previously moved embroidery motif which has been saved in the new position is opened in the saved position after selecting.



> Tap the Switch again.

- The embroidery motif is centered to the Embroidery Hoop.

Calibrating the embroidery hoop

The calibration of the embroidery hoop is the coordination of the needle to the center of the embroidery hoop.

Prerequisite:

- The embroidery module is connected and the embroidery hoop with the appropriate embroidery template is attached.



> Tap «Setup Program».



> Tap «Embroidery Settings».



> Tap «Calibrating the Embroidery Hoop».



> To delete the current calibration, tap «Deleting» (1).
> Center the needle via the arrow icons on the display.



Entering the fabric thickness

If the fabric thickness is more than 4 mm as for e.g. toweling, it is recommended to select 7.5 mm or 10 mm. The thicker the fabric, the slower the embroidery speed of the machine. When the machine is switched off, the alterations are reset to the basic setting 4 mm.



> Tap «Setup Program».







> Tap «Embroidery Settings».



> Tap «Entering the Fabric Thickness».
> Select fabric thickness.

Activating/Deactivating the function thread away








To bring up the thread end after cutting and to pull it out of the fabric, the function must be activated. For embroidery motifs with long stitches it is recommended to deactivate the function Thread Away. If the distance between the presser foot and the embroidery hoop is too small, the function will not be carried out.

-  > Tap «Setup Program».
-  > Tap «Embroidery Settings».
-  > Tap «Thread Away».
-  > Activating/Deactivating the function thread away.

Programming the securing stitches

Embroidery motifs are programmed either with or without securing stitches. If an embroidery motif has programmed securing stitches, they will be embroidered. If the embroidery motif is programmed with securing stitches, the securing stitches can be removed in the BERNINA Embroidery Software.

The machine recognizes when no securing stitches are programmed and adds them. If no securing stitches are wanted, they can be deactivated.

-  > Tap «Setup Program».
-  > Tap «Embroidery Settings».
-  > Tap «Securing Stitches».
-  > To deactivate the securing stitches at the start, switch off the switch in the upper section.
 - If the embroidery motif doesn't have any programmed securing stitches, none are embroidered.
-  > Turn on the switch in the upper section to deactivate the securing stitches at the start.
 - If the embroidery motif doesn't have any programmed securing stitches, the securing stitches are added and will be embroidered.
-  > Turn off the switch in the lower section to deactivate the securing stitches at the end.
 - If the embroidery motif doesn't have any programmed securing stitches, none are embroidered.
-  > Turn on the switch in the lower section to activate the securing stitches at the end.
 - If the embroidery motif doesn't have any programmed securing stitches, the securing stitches are added and will be embroidered.

Adjusting the thread cut


The settings for the thread cut can be customized. Deactivate the thread cut before a color change (1) or adjust the length of the connecting stitch (3). The machine does the cutting of the connecting threads at the determined length for you. First, set the length from which the connecting stitches are cut, and then select the embroidery design.




The length of the connecting thread can be adjusted between 1 mm and 15 mm, the default setting is 6 mm. This means that all connecting stitches longer than 6 mm are cut automatically. If the value is reduced to 1 mm, more thread cuts are carried out, it takes longer to embroider and more loose thread ends can be seen on the wrong side of the fabric, especially when the function 'Thread-away' is activated too. On the right side of the fabric there will be practically none or merely very short connecting stitches which results in a wonderful stitch formation. Reducing the length of the thread cut to 1 mm is particularly of advantage when embroidering texts where usually many short connecting threads occur. When both sides of the embroidery designs are visible, it may be reasonable to not reduce the length of the thread cut so much so that there won't be too many loose thread ends on the wrong side of the fabric. Loose ends get sewn over and can hardly be removed afterwards.


-  > Tap «Setup Program».

Setup Program

 > Tap «Embroidery Settings».

 > Tap «Thread Cut Settings».





-  > To deactivate the automatic thread cut before changing a thread, tap the switch in the upper section of the display (1).
- > To activate the automatic thread cut before changing a thread, tap the switch in the upper section of the display (1) again.
- > Tap the switch in the middle section of the display (2) so that the machine will stop after about 7 stitches and the remaining thread can be cut manually.
- > Tap the switch in the middle section of the display (2) again and the machine won't stop for a manual thread cut.
- > To adjust the length from where the connecting stitches are cut, tap «Minus» or «Plus» (3).

Changing the measuring unit

The measuring unit in the Embroidery Mode can be changed from mm to inch. The standard setting is in mm.

 > Tap «Setup Program».


 > Tap «Embroidery Settings».

-  > Tap «Measuring Unit».
- > To display the measurements in the Embroidery Mode in inch, tap «inch».
- > To display the measurements in the Embroidery Mode in mm, tap «mm».

3.3 Selecting personal settings



 > Tap «Setup Program».

-  > Tap «Personal Settings».
- > Select the required display color and background.

- > Tap the text box above the color settings.
- > Enter and confirm the welcome text.

3.4 Monitoring Functions

Activating the Upper Thread Indicator



- > Tap «Setup Program».



- > Tap «Monitoring Functions».



- > Tap the switch in the upper section of the display to deactivate the upper thread indicator.
- > Tap the switch again to activate the upper thread indicator.

Activating the Bobbin Thread Indicator



- > Tap «Setup Program».



- > Tap «Monitoring Functions».



- > Tap the switch in the lower section of the display to deactivate the bobbin thread indicator.
- > Tap the switch again to activate the bobbin thread indicator.

3.5 Activating the audio signals



- > Tap «Setup Program».



- > Tap «Setting Sound».
- > To switch all audio signals on or off, tap (1).



- > To switch off the sound when selecting a stitch pattern, tap the corresponding «Switching Sounds On/Off» in area (2).

> To switch on the sound when selecting a stitch pattern, tap the corresponding in area_(2) «1 – 4».



- > To switch off the sound for selecting functions, tap the corresponding «Switching Sounds On/Off» in area (3).

> To switch on the sound for selecting functions, tap the corresponding in area_(3) «1 – 4».



- > To deactivate the sound of the beeper when using the BSR Modes, tap «Switching Sounds On/Off» in the sector (4).

3.6 Machine Settings

Selecting a language

The User Interface can be programmed in different languages according to the customer's wish because BERNINA provides a wide range of international languages for the customers. Via firmware updates additional languages for the User Interface can be provided.



> Tap «Setup Program».



> Tap «Machine settings».



> Tap «Language Selection».

> Select a language.

Adjusting the Brightness of the Display

The brightness of the display can be set to meet your individual needs.



> Tap «Setup Program».



> Tap «Machine settings».



> Tap «Display Settings».

> Adjust the brightness of the display in the upper section of the screen.

Adjusting the Sewing Light

The brightness of the sewing light can be adjusted corresponding to the personal preferences.



> Tap «Setup Program».



> Tap «Machine settings».



> Tap «Display Settings».

> Adjust the brightness of the sewing light in the lower section of the screen.



> Tap the switch to switch the sewing light off.

> Tap the switch again to switch the sewing light on.

Calibrating the Display

You will find more information on this topic in the chapter "Troubleshooting". (see page 160)



> Tap «Setup Program».

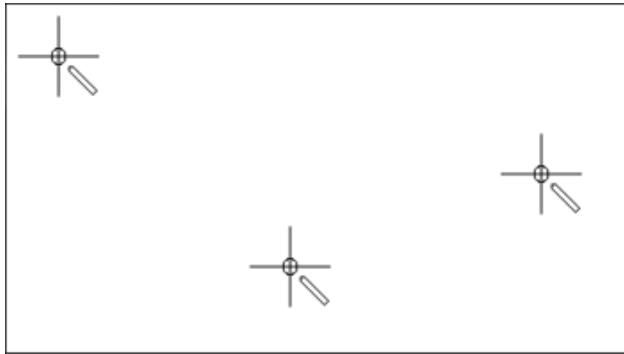


> Tap «Machine settings».



> Tap «Calibrating the Screen».

- > Touch the crosses in sequence using the touchscreen pen.



Back to Basic Setting

ATTENTION: Using this function will delete all individually made settings.



- > Tap «Setup Program».



- > Tap «Machine settings».



- > Tap «Factory Setting».



- > To restore all default settings for sewing, tap «Default Setting Sewing» and confirm.



- > To restore all default settings for embroidering, tap «Default Setting Embroidering» and confirm.



- > To restore all default settings, tap «Default Setting Machine», confirm and restart the machine.

Deleting user data



- > Tap «Setup Program».



- > Tap «Machine settings».



- > Tap «Factory Setting».



- > To delete all data from the Personal Memory, tap «Delete Data from Own Storage Medium» and confirm.



- > To delete all embroidery motifs from the Personal Memory, tap «Delete Personal Embroidery Designs» and confirm.

Deleting motifs on the BERNINA USB Stick

- > Insert the BERNINA USB stick into the USB Port of the machine.



- > Tap «Setup Program».



- > Tap «Machine settings».



- > Tap «Factory Setting».



- > Tap «Deleting USB Stick» and confirm.

Calibrating the Buttonhole Foot #3A

The Buttonhole Foot with Slide #3A is calibrated to the machine and they should only be used both together.

Prerequisite:

- The Buttonhole Foot with Slide #3A is fitted.
- The needle is not threaded.



> Tap «Setup Program».



> Tap «Machine settings».



> Tap «Maintenance/update».



> Tap «Calibrating the Buttonhole Foot #3A».



> To start the calibration, push the button «Start/Stop».
 – When the calibration is complete, the result is shown in the display.

Packing the embroidery module

To pack the embroidery module into the original packaging without moving the embroidery arm manually, the embroidery arm needs to be brought to its packing position.

Prerequisite:

- The embroidery module is connected with the machine.



> Tap «Setup Program».



> Tap «Machine settings».



> Tap «Maintenance/update».



> Tap «Packing Position».
 > Follow the instructions on the display.

Reviewing the total number of stitches

The total number of stitches by the machine and the number of stitches since the last maintenance carried out by a specialist BERNINA dealer are displayed.



> Tap «Setup Program».



> Tap «Machine settings».











> Tap «Information».



> Tap «Machine Data».






Registering details of the dealer

The contact details for your specialized BERNINA dealer can be entered.

-  > Tap «Setup Program».
-  > Tap «Machine settings».
-  > Tap «Information».
-  > To enter the dealer data, tap «Dealer Data».
-  > To enter the name of your specialized BERNINA dealer, tap «Name».
-  > To enter the address of the specialized BERNINA dealer, tap «Address».
-  > To enter the telephone number of the specialized BERNINA dealer, tap «Phone Number».
-  > To enter the website or e-mail address of the specialized BERNINA dealer, tap «E-mail address».

Saving Service data

The service data regarding the current status of the machine can be saved on a USB stick and consequently provided to the specialized BERNINA dealer.

- > Insert a USB stick which provides enough free capacity into the USB port of the machine.
-  > Tap «Setup Program».
-  > Tap «Machine settings».
-  > Tap «Information».
-  > Tap «Service Data».
-  > Tap «Export the Service Data».
 - The icon «Export the Service Data» is outlined in white.
- > If the white frame is no longer displayed, remove the USB stick.

4 System Settings

4.1 Calling Up the Tutorial

The Tutorial gives information and explanations, covering various aspects of sewing, embroidering, and the different stitches.



- > Tap «Tutorial».
- > Select the desired topic in order to view information.

4.2 Calling up the Creative Consultant

The Creative Consultant provides decision support for sewing projects. After entering the kind of fabric and the desired sewing project, suggestions concerning the suitable needle or the appropriate presser foot are displayed.



- > Tap «Creative Consultant».
- > Select the fabric on which you want to sew.
- > Select the sewing project.



- > Tap «Confirm».
- The settings are adjusted.

4.3 Calling Up the Help

> Touch the window in the display where help is needed.



- > To start the Help Mode, tap «Help» twice.
- > Tap the icon in the display where help is needed.

4.4 Using eco mode

During a longer interruption of work the machine can be set into a power save mode. The power save mode also serves as a child safety feature. Nothing can be selected in the display and the machine cannot be started.



- > To activate the power save mode, tap «eco Mode».
- The display goes to sleep. The power consumption is reduced and the sewing light is off.
- > To deactivate the power save mode, tap «eco Mode» again.

4.5 Cancelling Any Alterations with «clr»

Any alterations to designs can be reset to basic setting. Exceptions are saved designs which have been filed in the personal memory and monitoring functions.



- > Tap «Clear Settings».

5 Creative Sewing

5.1 Overview selection menu sewing



- | | | | |
|---|-----------------------|---|-------------------|
| 1 | «Practical Stitches» | 5 | «Quilt Stitches» |
| 2 | «Decorative Stitches» | 6 | «Personal Memory» |
| 3 | «Alphabets» | 7 | «History» |
| 4 | «Buttonholes» | | |

Selecting a stitch pattern

- > Select a stitch pattern, alphabet or buttonhole.
- > To increase the view, tap «Increasing/Decreasing the Display Size» (1).



- > To decrease the view, tap «Increasing/Decreasing the Display Size» again.
- > To select the stitch pattern via the stitch number entry, tap «Stitch Pattern Selection via Number».

5.2 BERNINA Dual Feed

The BERNINA Dual Feed feeds the fabric from above and from beneath simultaneously. This provides an even and careful feed forward even for smooth and thin materials. Striped and checkered patterns can be matched perfectly by even feeding.

In general, the BERNINA Dual Feed is used for the following sewing projects:

- Sewing: All sewing applications with difficult fabrics, e. g. seams, zippers.
- Patchwork: With accurate stripes, blocks and with decorative stitches up to a stitch width of 9 mm.
- Appliqués: Sewing on ribbons and bias binding.

Difficult-to-work-with fabrics are:

- Velvet, normally sewn with the grain.
- Toweling.
- Jersey, especially when sewing it crosswise to knit.
- Fake fur or coated fake fur.
- Fleece-types of fabrics.

- Batted fabrics.
- Stripes and checks.
- Curtain fabrics with pattern repeats.

«Sticky» fabrics are:

- Imitation leather, coated fabrics (optimally with optional accessory Zigzag Foot with Non-Stick Sole #52D).

Switching on/off the BERNINA Dual Feed

Only use the Dual Feed presser feet with a cut-out at the center back and the labeling «D».

Activating the BERNINA Dual Feed

- > Raise the presser foot.
- > Attach a presser foot with the designation «D».
- > Pull the dual feed down until it engages.



Deactivating the BERNINA Dual Feed

- > Raise the presser foot.
- > Hold the dual feed by the handle with two fingers, pull it down and then push it away from you and let it slide slowly upwards.



5.3 Regulating the Speed

The sewing speed can be adjusted infinitely variable with the slide.

- > Move the slide to the left to reduce the sewing speed.
- > Move the slide to the right to increase the sewing speed.



5.4 Adjusting the upper thread tension

The default setting of the upper thread tension is set automatically as soon as a stitch pattern or an embroidery motif is selected.

The upper thread tension is set optimally at the BERNINA factory and the machine has been tested. Metrosene-/Seralon thread size 100/2 (Company Mettler, Switzerland) is used for upper and bobbin thread.

When of using other types of sewing or embroidery threads, the optimal tension may vary. Therefore it may be necessary to adjust the upper thread tension according to the sewing or embroidering project as well as the desired stitch pattern or the embroidery motif individually.

The higher the upper thread tension, the tighter the upper thread which means that the bobbin thread is pulled up to the top of the fabric. When the upper thread tension is low, the upper thread is less tightened which means that the bobbin thread is pulled up less.

Alteration to the upper thread tension affect the currently selected stitch pattern or embroidery motif. Permanent alterations of the upper thread tension for the Sewing Mode (see page 48) and for the Embroidering Mode (see page 51) can be made in the Setup Program.

Prerequisite:

- The upper thread tension has been altered in the setup program.



- > Tap «Upper Thread Tension».
- > Adjust the upper thread tension.



- > Tap the yellow-outlined icon on the right side to reset the alterations to the default setting.
- > Tap the yellow-outlined icon on the left side to reset the alteration to default setting in the **Setup Program**.

5.5 Editing Stitch Patterns

Changing the Stitch Width

- > Turn the «Upper Multi-function Knob» to the left to narrow the stitch width.
- > Turn the «Upper Multi-function Knob» to the right to widen the stitch width.
- > To call up further setting options, tap the icon «Stitch width» (1).



Changing the Stitch Length

- > Turn the «Lower Multi-function Knob» to the left to shorten the stitch length.
- > Turn the «Lower Multi-function Knob» to the right to elongate the stitch length.
- > To call up other setting options, tap «Stitch Length» (1).



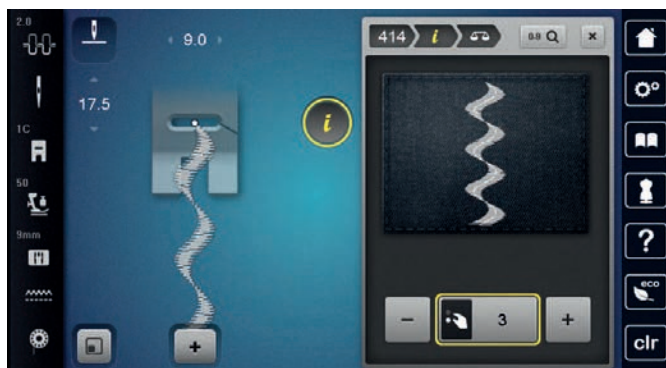
Correcting the Balance

Different fabrics, threads and stabilizers can affect the programmed stitch patterns so that they cannot be sewn out correctly. The electronic balance can correct these deviation and the stitch pattern can be adjusted optimally to the selected fabric.

- > Select a stitch pattern or alphabet.
- > Sewing stitch pattern.
- > Tap «i-Dialog».



- > Tap «Balance».
 - A preview of the stitch pattern is displayed.



- > To correct the longitudinal direction of the stitch pattern, turn the «Lower Multi-function Knob» until the preview of the stitch pattern matches the stitch pattern sewn on the fabric.



- > Altered Balance settings can be saved for each stitch in the «Personal Memory» .
- > Altered Balance settings only remain valid until the «Clear Settings» is pushed or the machine is switched off.

Programming Pattern Repeat

Stitch patterns can be repeated up to 99 times.

- > Select a stitch pattern or alphabet.
- > Tap «i-Dialog».



- > Tap «Pattern Repeat».
- > Enter the required number of stitch patterns.



- > Tap «Confirm».



- > To deactivate the pattern repeat, tap and hold «Pattern Repeat».

Programming long stitch

The maximum length for long stitches is 12 mm and the machine sews every second stitch.



- > Select a stitch pattern.
- > Tap «i-Dialog».



- > Tap «Long stitch».

Mirror Image of Stitch Patterns



- > Select a stitch pattern or alphabet.
- > Tap «i-Dialog».



- > To mirror the stitch pattern from left to right, tap «Mirror Image Left/Right».



- > To mirror the stitch pattern in sewing direction, tap «Mirror Image Up/Down».

Edit Stitch Pattern Length

The stitch patterns can be lengthwise extended or shortened.



- > Select a stitch pattern or alphabet.
- > Tap «i-Dialog».



- > Tap «Edit Stitch Pattern Length».
- > Adjust the stitch pattern length.

Programming the Stitch Counter Function

The Stitch Counter function cannot be set for all stitch patterns. If, for example, the Honeycomb Stitch No. 8 is selected, the stitch counter function cannot be used.



- > Select the stitch pattern.
- > Tap «i-Dialog».



- > Tap «Programming the Length via the Stitch Counter».
- > Sew the desired length.



- > Push the button «Quick Reverse».
 - The display changes to «Auto» and the selected stitch pattern in the new length is saved until the machine is switched off.

Sewing Stitch Patterns Using the Triple Stitch

The stitch pattern can be sewn three times for a more attractive result. Not all stitch patterns can be sewn using the triple stitch.



- > Select the stitch pattern.
- > Tap «i-Dialog».



- > Tap «Triple Stitch».

Quick Reverse

- > Select a stitch pattern or alphabet.
- > To switch immediately to sewing in reverse when pushing the button «Quick Reverse», select Needle Stop Down (permanent).
- > Program needle stop up (permanent) to sew another stitch forward before the machine switches to reverse sewing.



- > Push and hold the button «Quick Reverse».

Permanent Quick Reverse

- > Select a stitch pattern or alphabet.
- > Tap «i-Dialog».



- > To sew permanently in reverse, tap «Quick Reverse».
 - The machine sews permanently in reverse until «Quick Reverse» is tapped again.

Backstepping

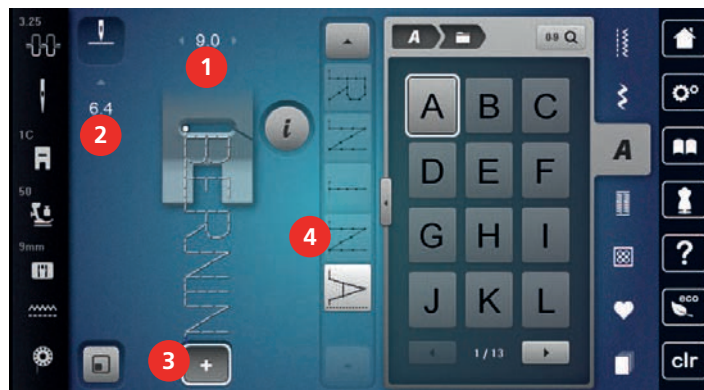
- > Select a stitch pattern or alphabet.
- > Tap «i-Dialog».



- > To backstep the last 200 stitches, tap «Back Stepping».

5.6 Combining stitch patterns

Overview Combi Mode



- | | | | |
|---|-----------------|---|--|
| 1 | «Stitch Width» | 3 | «Combination Mode/Single Mode» |
| 2 | «Stitch Length» | 4 | Individual Stitch Pattern within the Combination |

Creating Stitch Pattern Combinations

In the Combi Mode stitch patterns and alphabets can be combined according to your wish. By combining any alphabet letters, the logo BERNINA can be created.



- > Tap «Combination Mode/Single Mode».

> Select the desired stitch patterns.



> To get back to the Single Mode, tap «Combination Mode/Single Mode» again.

Saving a Stitch Pattern Combination

To use an individually created stitch pattern combinations again, they can be saved in the folder «Personal Memory».

Prerequisite:

- A stitch pattern combination has been created.



> Tap «Personal Memory».



> Tap «Save Stitch Pattern».



> To save the stitch pattern combination, tap «Confirm».

Loading a Stitch Pattern Combination



> Tap «Combination Mode/Single Mode».



> Tap «Personal Memory».



> Tap «Loading a Stitch Pattern Combination».
> Select a stitch pattern combination.

Overwriting a Stitch Pattern Combination

Prerequisite:

- A stitch pattern combination has been created.



> Tap «Personal Memory».



> Tap «Save Stitch Pattern».
> Select the stitch pattern combination which is to be overwritten.



> To overwrite the stitch pattern combination, tap «Confirm».

Deleting a Stitch Pattern Combination

Prerequisite:

- A stitch pattern combination has been created.



> Tap «i-Dialog».



> Tap «Edit Entire Combination».



> Tap «Deleting».



> Tap «Confirm».

Editing a Single Stitch Pattern

Prerequisite:

- A stitch pattern combination has been created.

> To select a single stitch pattern, tap the desired position (1) within the stitch pattern combination.



> To edit the single stitch pattern, tap «i-Dialog».

Deleting a Single Stitch Pattern

Prerequisite:

- A stitch pattern combination has been created.

> Tap the desired stitch pattern (1) within the stitch pattern combination.



> Tap «i-Dialog».



> Tap «Deleting».

Adding a Single Stitch Pattern

The new stitch pattern is always inserted after the selected stitch pattern.

Prerequisite:

- A stitch pattern combination has been created.
- > To select a single stitch pattern, tap the desired position (1) within the stitch pattern combination.



- > Select a new stitch pattern.

Adapting the Stitch Pattern length and Stitch Pattern Width

The length and width of the individual stitch patterns in a stitch pattern combination can be adapted to the longest and widest stitch patterns in the combination.

Prerequisite:

- A stitch pattern combination has been created.



- > Tap «i-Dialog».



- > Tap «Edit Entire Combination».
> Tap «Total Pattern Length» (1).



- > Tap «Adjust Length within the Combination» (2).
– The lengths of the stitch patterns are adapted to the length of the longest stitch pattern in the combination.

- > Tap «Stitch Width» (3).



- > Tap «Adjust Width within the Combination» (4).
 - The widths of all of the stitch patterns are adapted to the width of the widest stitch pattern in the combination.

Furthermore, the length and width of the stitch pattern combination are increased or decreased proportionally.

- > To decrease the width of the stitch pattern combination proportionally, turn the «Upper Multi-function knob» to the left.
- > To increase the width of the stitch pattern combination proportionally, turn the «Upper Multi-function knob» to the right.
- > To decrease the length of the stitch pattern combination proportionally, turn the «Lower Multi-function knob» to the left.
- > To increase the length of the stitch pattern combination proportionally, turn the «Lower Multi-function knob» to the right.

Mirroring a Stitch Pattern Combination

Prerequisite:

- A stitch pattern combination has been created.



- > Tap «i-Dialog».



- > Tap «Edit Entire Combination».



- > To mirror the whole stitch pattern combination from left to right, tap, «Mirror Image Left/Right».
- > To reset the changes and revert to the default settings, tap «Mirror Image Left/Right».

Stitch Pattern Combination Subdivider 1

A stitch pattern combination can be subdivided into several sections. The subdivision is inserted below the cursor. Only the section in which the cursor is placed will be sewn. To sew the next section, the cursor must be placed in this section.

Prerequisite:

- A stitch pattern combination has been created.
- > Select the desired position within the stitch pattern combination where the stitch pattern combination is to be subdivided.



- > Tap «i-Dialog».



- > Tap «Edit Combination at Cursor Position».



- > Tap «Combination Subdivider (1)».



Stitch Pattern Combination Subdivider 2

A stitch pattern combination can be interrupted at different positions. The interruption is inserted below the cursor.

Prerequisite:

- A stitch pattern combination has been created.
- > Select the desired position within the stitch pattern combination where the stitch pattern combination is to be interrupted.
- > Tap «i-Dialog».



- > Tap «Edit Combination at Cursor Position».



- > Tap «Combination Subdivider (2)».
- > Sew stitch pattern combination up to the interruption and reposition the fabric.

Securing a Stitch Pattern Combination

Prerequisite:

- A stitch pattern combination has been created.
- > Select the desired position within the stitch pattern combination where the stitch pattern combination is to be secured.
- > Tap «i-Dialog».



- > Tap «Edit Combination at Cursor Position».



- > Tap «Securing Stitches».
 - Every single pattern of the stitch pattern combination can be secured at the start or at the end.

Programming Pattern Repeat

Prerequisite:

- A stitch pattern combination has been created.
- > Tap «i-Dialog».



- > Tap «Edit Entire Combination».



- > To repeat the stitch pattern combination, tap «Pattern Repeat» 1x.
- > To repeat the stitch pattern combination up to 9x, tap «Pattern Repeat» again.
- > To deactivate the pattern repeat, tap and hold «Pattern Repeat» or tap «Clear Settings».

5.7 Administering Stitch Patterns

Saving Settings of Stitch Patterns

- > Select a stitch pattern, alphabet or buttonhole.
- > Tap «i-Dialog».
- > Edit the stitch, alphabet or buttonhole.



- > To save all alterations permanently, tap «Saving Settings of Stitch Patterns».



- > To cancel all alterations, tap «Reset Stitch Pattern».

Calling up the previously sewn stitch patterns

The 15 previously sewn stitch patterns are saved automatically and can be called up at any time.



- > To display the previously sewn stitch patterns, tap «History».
- > Select a stitch pattern.

Saving Stitch Patterns in Personal Memory

In the folder «Personal Memory» any stitch patterns, also those which have been individually edited, can be saved.

- > Select a stitch pattern, alphabet or buttonhole.
- > Edit the stitch pattern.
- > Tap «Personal Memory».



- > Tap «Save Stitch Pattern».
- > Select the file where the pattern is to be saved.



- > Tap «Confirm».

Overwriting Stitch Patterns from the Personal Memory

Prerequisite:

- The stitch pattern is saved in the personal memory.
- > Select a stitch pattern, alphabet or buttonhole.
- > Edit the stitch pattern.
- > Tap «Personal Memory».



- > Tap «Save Stitch Pattern».
- > Select the file where the stitch pattern to be overwritten has been saved.
- > Select the stitch pattern which should be overwritten.



- > Tap «Confirm».

Loading Stitch Patterns from the Personal Memory

Prerequisite:

- The stitch pattern is saved in the personal memory.



- > Tap «Personal Memory».



- > Tap «Load Embroidery Design».
- > Select the file where the stitch pattern has been saved.
- > Select the stitch pattern.

Deleting Stitch Patterns from the Personal Memory

Prerequisite:

- The stitch pattern is saved in the personal memory.



- > Tap «Personal Memory».



- > Tap «Deleting».
- > Select the file where the stitch pattern has been saved.
- > Select the stitch pattern.



- > To delete the stitch pattern, tap «Confirm».

Saving Stitch Patterns on the BERNINA USB Stick

On the BERNINA USB stick stitch patterns, also those which have been individually edited, can be saved.

- > Select a stitch pattern or alphabet.
- > Editing stitch patterns.
- > Tap «Personal Memory».



- > Tap «Save Stitch Pattern».
- > Insert the BERNINA USB stick into the USB port of the machine.



- > Tap «USB Stick».



- > Tap «Confirm».

Uploading a Stitch Pattern from the BERNINA USB Stick

- > Tap «Personal Memory».



- > Tap «Load Embroidery Design».
- > Tap «Increasing/Decreasing the Display Size» (1).



- > Insert the BERNINA USB stick into the USB port of the machine.
- > Tap «USB Stick».
- > Select the desired stitch pattern.



Deleting Stitch Patterns from the BERNINA USB Stick

- > Tap «Personal Memory».



- > Tap «Deleting».
- > Insert the BERNINA USB stick into the USB port of the machine.
- > Select the stitch pattern which is to be deleted.



- > Tap «Confirm».

5.8 Securing Stitches

Securing a seam with the button «Securing»

The «Securing Stitches» button can be programmed with various securing stitches.



- > Pressing the «Securing Stitches» button before starting to sew.
 - The stitch pattern/stitch pattern combination is secured with the number of programmed stitches when sewing is started.
- > Press the «Securing Stitches» button while sewing.
 - The machine stops immediately and secures with the number of programmed stitches.

Securing with the Button «Pattern End»

The «Pattern End» button can be programmed with various securing stitches.

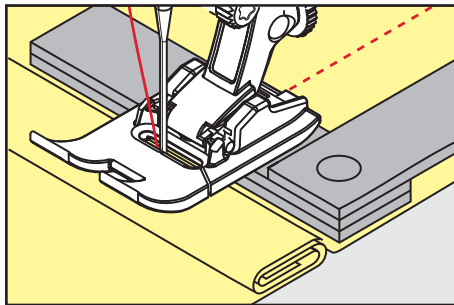


- > Push the button «Pattern End» before sewing is started or while sewing.
 - While sewing, a stop icon indicates that the function is activated and the stitch pattern or the current combination of a stitch pattern will be secured at the end with the programmed number of stitches.

5.9 Height Compensation of Uneven Layers

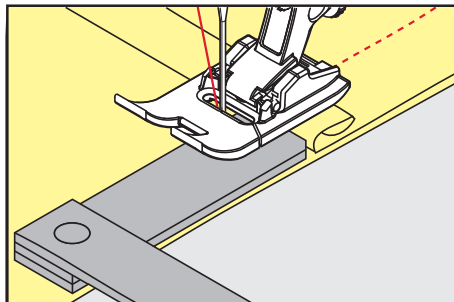
If the presser foot is at an angle when sewing over a thick seam, the feed dog cannot grip the fabric and the sewing project cannot be sewn out properly.

- > Place 1 – 3 compensating plates as required from the back of the presser foot close to the needle to level the fabric layer.



- The presser foot is leveled with the sewing project.

- > Place 1 – 3 compensating plates as required from the front of the presser foot close to the needle to level the fabric layer.



- The presser foot is leveled with the sewing project.

- > Sew until the complete presser foot has passed the thick seam.
- > Remove the plates of the height compensation.

5.10 Sewing Corners

When sewing corners, only a small section of the fabric is actually on the feed dog. Therefore it cannot grip the fabric well. By means of the height compensation tool the fabric can be fed evenly.
















- > When the fabric edge is reached, stop the sewing process with needle position down.
- > Raise the presser foot.
- > Turn the fabric and place in desired position.
- > Place 1 – 3 compensating plates as required on the right of the presser foot close to the sewing project.

6 Practical Stitches













6.1 Overview Practical Stitches



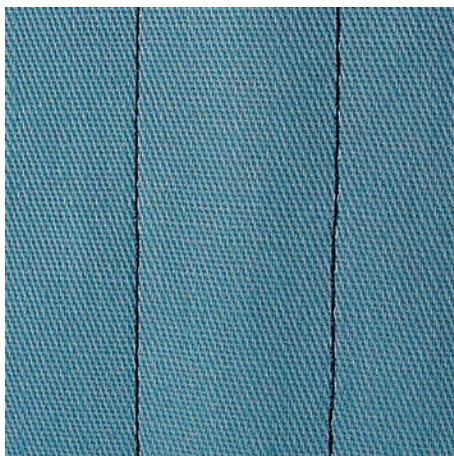
Stitch patterns	Stitch number	Name	Description
	1	Straight Stitch	To join seams, for topstitching and basting.
	2	Zigzag	To finish edges, to sew elastic seams, to sew on lace inserts and elastics.
	3	Vari-Overlock	For finishing edges, sewing together and simultaneously finishing elastic fabrics.
	4	Running Stitch	For darning and reinforcing fabric edges or attaching lace or rubber tape.
	5	Securing Program	For automatic securing at the start of the seam with forward and reverse stitches.
	6	Triple Straight Stitch	For reinforced seams on heavy fabrics and decorative effects.
	7	Triple Zig zag	For durable seams on strong fabrics, visible hems and decorative seams.
	8	Honeycomb Stitch	For stretch fabrics and hems, including with rubber threads.
	9	Blind Stitch	For blind hems on most fabric types and for shell edging on soft jerseys and fine fabric.
	10	Double Overlock	For simultaneously sewing together and finishing elastic fabrics.
	11	Superstretch Stitch	For highly stretch open seams.

	12	Gathering Stitch	For gathering with rubber threads and for flat joining seams on medium-weight fabrics.
	13	Stretch Overlock	For simultaneously sewing together and finishing elastic fabrics, as well as for flat joining seams.
	14	Tricot Stitch	For visible hems and seams in lingerie and sweaters and for mending tricot fabric.
	15	Universal Stitch	For flat joining seams, visible hems and decorative seams in strong fabrics such as felt and leather and for attaching rubber tape.
	16	Sewn-out Zigzag	For finishing and reinforcing fabric edges, for sewing on rubber tape and for decorative seams.
	17	Lycra Stitch	For flat joining seams, visible hems on Lycra fabric and for stitching over seams in foundation garments.
	18	Stretch Stitch	For stretchable seams and hems in woven and knitted fabrics.
	19	Reinforced Overlock	For overlock seams or flat joining seams on medium-weight knit fabrics and toweling.
	20	Knit Overlock	For stretchable seams and hems in woven and knitted fabric, for sewing and finishing.
	21	Basting stitch	For tacking seams and hems and for quilting projects.
	22	Simple Darning Program	For automatic darning in fine to strong fabrics.
	23	Reinforced Darning Program	For automatic darning in strong materials.
	24	Bartack Program	For reinforcing pocket openings, buttonhole bars and for sewing belt loops.
	25	Bartack Program	For reinforcing pocket openings, sewing belt loops and securing seam ends.
	26	Large Fly Stitch	For reinforcing pocket openings, zippers and slits in medium-weight to thick fabrics.



	27	Small Fly Stitch	For reinforcing pocket openings, zippers and slits in fine to medium-weight fabrics.
	29	Narrow Blind Stitch	For blind hems and shell edging in light, fine and soft fabrics.
	31	Triple straight stitch with long stitch	For durable seams in strong fabrics, e.g. visible and decorative seams.
	32	Single Straight Stitch	As a connecting stitch in a combination for one straight stitch.
	33	Three Single Straight Stitches	As connecting stitches in a combination for three individual straight stitches.
	34	Darning Stitch	For darning together with the function "Quick Reverse".
	35	Open Overlock Stitch	For simultaneously sewing together and finishing elastic fabrics with a reinforced edge.
	36	Overlock	For medium-weight knitted goods.
	37	Reinforced Overlock Stitch	For simultaneously sewing together, finishing and reinforcing elastic fabrics.
	38	Chain stitch	For decorative and reinforcing stitches on most woven fabrics.
	39	Cover stitch effect	To sew decorative seams and hems in heavy knitted goods and woven fabrics.
	40	Cover stitch effect	To sew decorative seams and hems in heavy knitted goods and woven fabrics.

6.2 Sewing Straight Stitch





Adjust the stitch length for the sewing project, e.g. a long stitch for denim (approx. 3 – 4 mm) and a short stitch for delicate fabric (approx. 2 – 2.5 mm). Adjust the stitch length depending on the thread thickness, e.g. a long stitch (approx. 3 – 5 mm) for top-stitching with gimp.

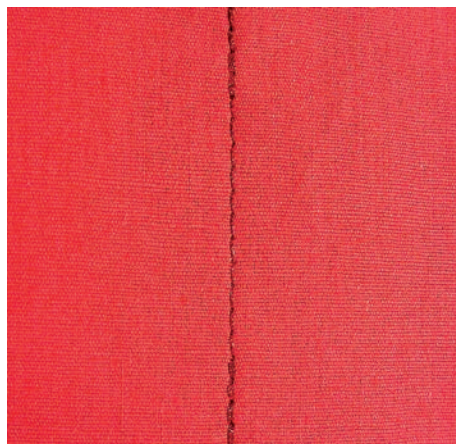
Prerequisite:

- The Reverse Pattern Foot #1C/1D is fitted.



- > Tap «Practical Stitches».
- > Select Straight Stitch No. 1.

6.3 Securing with the Automatic Securing Program



Due to a determined number of 6 stitches sewn forwards and 6 stitches sewn in reverse, the securing is regular.

Prerequisite:

- The Reverse Pattern Foot #1C is fitted.

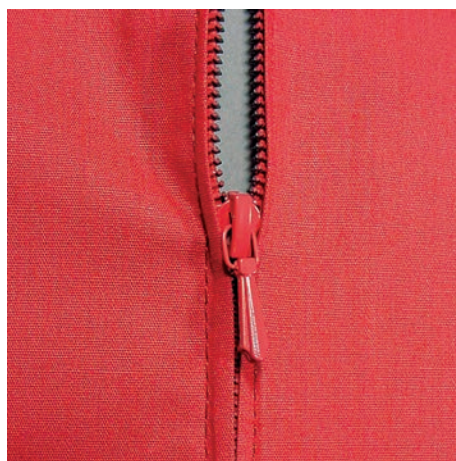


- > Tap «Practical Stitches».
- > Select Securing Program No. 5.
- > Press the foot control.
 - The machine secures automatically.



- > Sew the seam at the desired length.
- > Push the button «Quick Reverse».
 - The machine secures automatically and stops at the end of the securing program.

6.4 Sewing in the Zipper

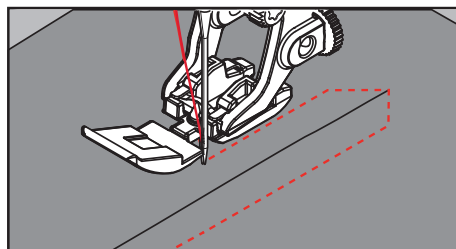




As the fabric feed can be difficult when starting to sew, it is recommended to hold the threads firmly or to pull the fabric slightly to the back for a few stitches or to sew 1 – 2 cm reverse first.



- > Fit the Reverse Pattern Foot #1C.
- > Tap «Practical Stitches».
- > Select Straight Stitch No. 1.
- > Sew the seam up to where the zipper starts.
- > Sew the securing stitches.
- > Close the zipper length with long stitches.
- > Finish the seam allowances.
- > Iron the seam.
- > Open the zipper length.
- > Baste the zipper under the fabric so that the fabric folded edges meet over the center of the zipper.
- > Open the zipper a few centimeters.
- > Fit the Zipper Foot #4D.
- > Move the needle position to the right.
- > Use the Free Hand System to raise the presser foot and to position the sewing project.
- > Start sewing from top left.
- > Guide the foot so that the needle stitches along the zipper coils.
- > Stop in front of the zipper pull with needle position down.
- > Raise the presser foot.
- > Close the zipper.
- > Continue to sew and stop in front of the base of the zipper with needle position down.
- > Raise the presser foot and turn the sewing project.
- > Sew across the other side of the zipper and stop with needle position down.
- > Raise the presser foot and turn the sewing project.
- > Sew the second side from bottom to top.



6.5 Sewing Both Sides of the Zipper from Bottom to Top

For fabrics with pile, such as velvet, it is recommended to sew in the zipper on both sides from bottom to top.



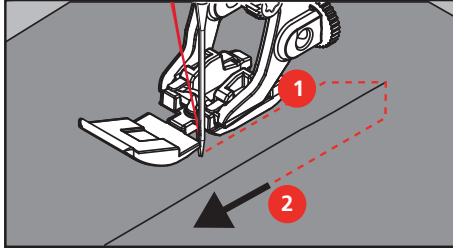
When the fabric is firm or densely woven, it is recommended to use a needle with the size 90 – 100. This results in an even stitch formation.



- > Fit the Reverse Pattern Foot #1C.
- > Tap «Practical Stitches».
- > Select Straight Stitch No. 1.
- > Sew the seam up to where the zipper starts.
- > Sew the securing stitches.
- > Close the zipper length with long stitches.
- > Finish the seam allowances.
- > Iron the seam.
- > Open the zipper length.
- > Baste the zipper under the fabric so that the fabric folded edges meet over the center of the zipper.
- > Fit the Zipper Foot #4D.
- > Move the needle position to the right.
- > Use the Free Hand System to raise the presser foot and to position the sewing project.



- > Start sewing in the center of the seam at the end of the zipper.
- > Sew diagonally along the edge of the zipper coils.
- > Sew the first side (1) from bottom to top.
- > Stop in front of the zipper pull with needle position down.
- > Raise the presser foot.
- > Open the zipper as far as behind the presser foot.
- > Lower the presser foot and continue sewing.
- > Move the needle position to the left.
- > Sew the second side (2) in exactly the same way from bottom to top.



6.6 Sewing Triple Straight Stitch

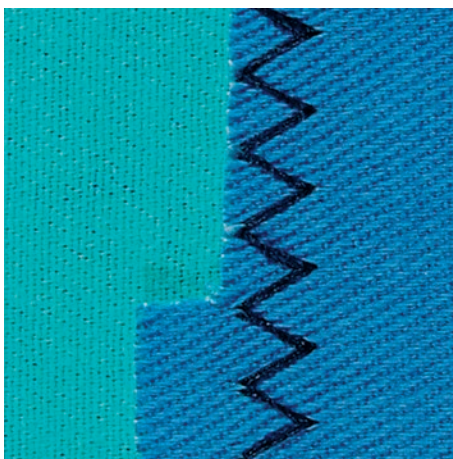


The triple straight stitch is especially suitable for durable seams and for firm, densely woven fabrics such as denim and corduroy. For firm or densely woven materials, it is recommended to fit the Jeans Foot #8. This will help to sew denim or canvas. For decorative topstitching, the stitch length can be elongated.

- > Fit the Reverse Pattern Foot #1C/1D.
- > Tap «Practical Stitches».
- > Select Triple Straight Stitch No. 6.



6.7 Sewing Triple Zigzag

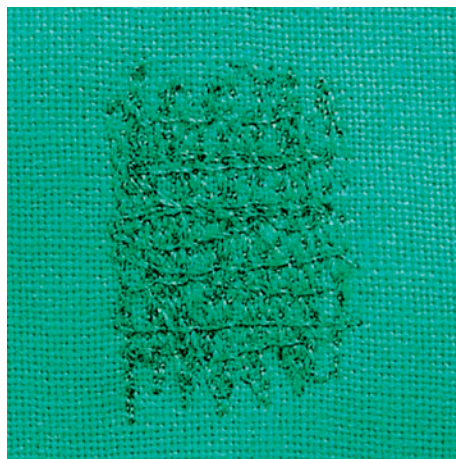


In firm fabrics, particularly for denim fabrics, deckchair covers, awnings. Hems on items that are frequently washed. Finish the seam edges first.

- > Fit the Reverse Pattern Foot #1C/1D.
- > Tap «Practical Stitches».
- > Select Triple Zig zag No. 7.



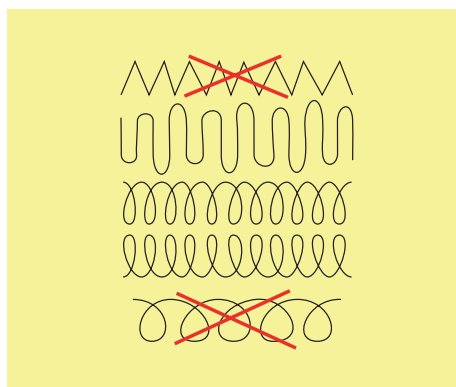
6.8 Manual Darning



Used for darning holes or worn areas in all fabric types.

If the thread is lying on top and a poor stitch formation results, slow down the movement of the sewing project. If there are knots on the wrong side of the fabric, move the sewing project faster. When the thread breaks, guide the sewing project more consistently.

- > Fit the Darning Foot #9.
- > Tap «Practical Stitches».
- > Select Straight Stitch No. 1.
- > Lower the feed dog.
- > Attach the Slide-on Freearm Extension Table.
- > Hoop the sewing project in the round embroidery hoop (optional accessory).
 - The darning area stays evenly taut and cannot be distorted.
- > Sew from the left to the right, guide the fabric evenly by hand without using pressure.
- > Move in curves when changing the direction to avoid holes and thread breakage.
- > Work the edges in irregular lengths so that the thread is better spread over the fabric.



- > Sew the first rows not too close together and beyond the worn area.

6.9 Automatic Darning



The Simple Darning Program No. 22 is particularly suitable for quick darning of worn areas or tears. It is recommended to use fine material as a backing for the worn and damaged areas or to stick an adhesive interlining. The Simple Darning Program No. 22 replaces the longitudinal threads in all fabrics. If the darning area becomes distorted, correct with the balance.



- > Fit the Reverse Pattern Foot #1C or Buttonhole Foot with Slide #3A.
- > Tap «Practical Stitches».
- > Select Simple Darning Program No. 22.
- > Hoop light-weight materials in the round embroidery hoop (optional accessory).
 - The darning area stays evenly taut and cannot be distorted.
- > Start sewing top left.
- > Sew the first row.
- > Stop the machine.



- > Push the button «Quick Reverse».
 - The length is programmed.
- > Finish sewing the Darning Program.
 - The machine stops automatically.

6.10 Reinforced Darning, Automatic



The Reinforced Darning Program No. 23 is particularly suitable for quick darning of worn areas or tears. The Reinforced Darning Program No. 23 replaces the longitudinal threads in all fabrics.



If the Darning Program does not cover the whole worn or damaged area, it is recommended to reposition the work and sew the Darning Program again. The length is programmed and can be repeated as often as desired.

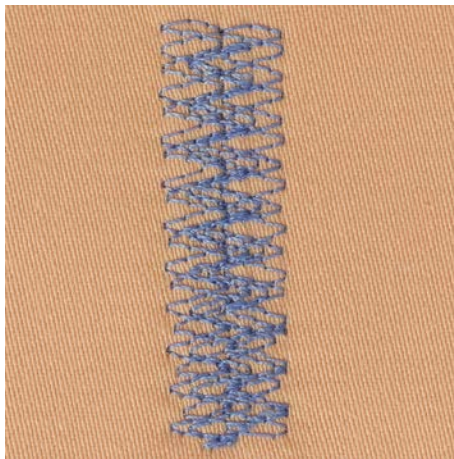


- > Fit the Buttonhole Foot with Slide #3A.
- > Tap «Practical Stitches».
- > Select Reinforced Darning Program No. 23.
- > Hoop light-weight materials in the round embroidery hoop (optional accessory).
 - The darning area stays evenly taut and cannot be distorted.
- > Start sewing top left.
- > Sew the first row.
- > Stop the machine.



- > Push the button «Quick Reverse».
 - The darning length is programmed.
- > Finish sewing the Darning Program.
 - The machine stops automatically.

6.11 Reinforced Darning



The Darning Stitch No. 34 is particularly suitable for damaged areas on heavy or strong fabrics, e. g. jeans and work clothes.



- > Fit the Reverse Pattern Foot #1C.
- > Tap «Practical Stitches».
- > Select Darning Stitch No. 34.
- > Sew the first row. Start at the top left.



- > When the desired length is reached, push the button «Quick Reverse».
 - The machine sews in reverse.



- > When the desired length is reached, push the button «Quick Reverse» again.
- > Repeat the process until the desired width is filled.

6.12 Finishing Edges



Zigzag No. 2 is suitable for all fabrics. It can be used for elastic seams as well as for decorative work. Use darning thread for fine materials. When sewing satin stitch, it is recommended to set a short, dense zigzag at a stitch length of 0.3 – 0.7 mm. The satin stitch can be used for appliqué and for embroidering.

Prerequisite:

- The edge of the fabric should lie flat and not roll.
- > Fit the Reverse Pattern Foot #1C.
- > Tap «Practical Stitches».
- > Select Zigzag No. 2 or Satin Stitch No. 1315.
- > Neither select too wide a stitch nor too long a stitch.
- > Guide the edge of the fabric into the center of the presser foot, so that the needle goes into the fabric on one side and over the edge into the air on the other side.



6.13 Sewing Double overlock



A double overlock seam is suitable for loose knits and cross seams in knits. When working with jersey, a jersey needle should be used to prevent damaging the knit fabric. When sewing stretch materials, use a stretch needle.

- > Fit the Reverse Pattern Foot #1C or Overlock Foot #2.
- > Tap «Practical Stitches».
- > Select Double Overlock No. 10.

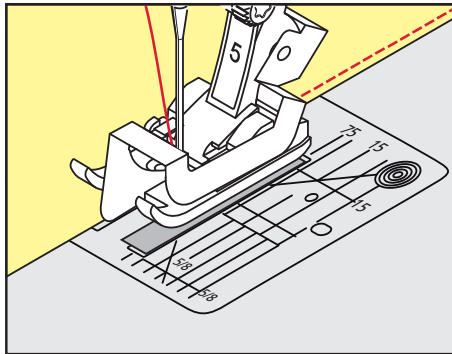


6.14 Narrow Edgestitching

- > Fit the Blindstitch Foot #5 or Edgestitch Foot #10/10C/10D.
- > Tap «Practical Stitches».
- > Select Straight Stitch No. 1.

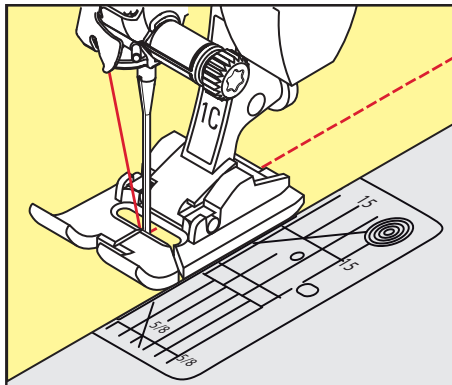


- > Place the edge against the left-hand guide of the Blindstitch Foot.
- > Select the left-hand needle position at the desired distance to the edge.



6.15 Wide Edgestitching

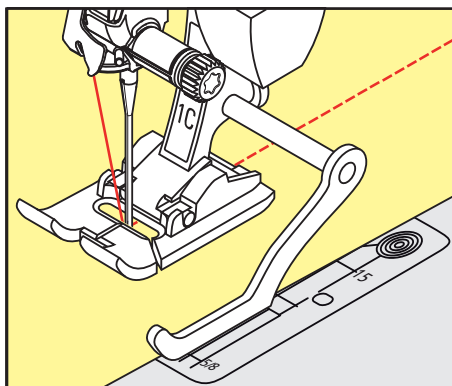
- > Fit the Reverse Pattern Foot #1C.
- > Tap «Practical Stitches».
- > Select Straight Stitch No. 1.
- > Guide the edge along the presser foot or at a distance of 1 – 2.5 cm along the marks on the stitch plate.
- > Select the needle position at the desired distance to the edge.



6.16 Edgestitching using the seam guide

When sewing parallel wider lines, it is recommended to guide the seam guide along the sewn of lines.

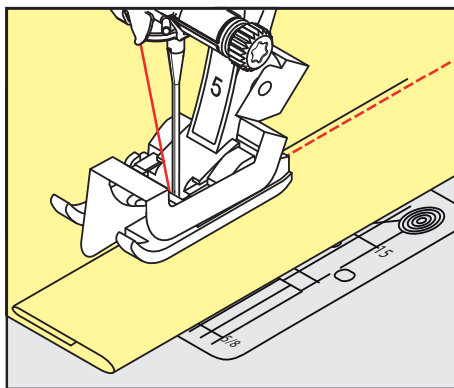
- > Fit the Reverse Pattern Foot #1C.
- > Tap «Practical Stitches».
- > Select Straight Stitch No. 1.
- > Loosen the screw on the back of the presser foot.
- > Insert the seam guide into the hole in the presser foot.
- > Adjust the width as required.
- > Tighten the screw.
- > Guide the folded edge along the seam guide.



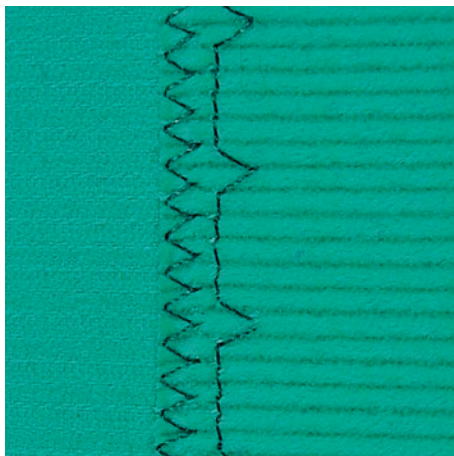
6.17 Sewing hem edges

When using the Blindstitch Foot #5, it is recommended to set the needle position far left or far right. With the Reverse Pattern Foot #1C and the Edgestitch Foot #10/10C/10D, all needle positions are possible.

- > Fit the Blindstitch Foot #5 or the Reverse Pattern Foot #1C or the Edgestitch Foot #10/10C/10D.
- > Tap «Practical Stitches».
- > Select Straight Stitch No. 1.
- > Place the inside upper edge right against the guide for the Blindstitch foot.
- > Select the needle position to the far right in order to sew along the upper edge.



6.18 Sewing blind hems



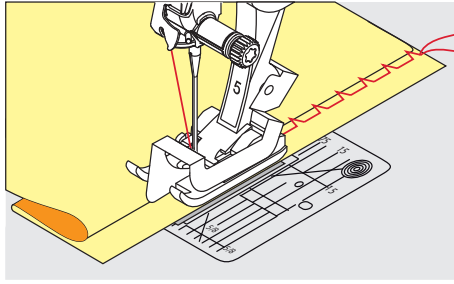
For invisible hems in medium to heavy weight cotton, wool and blended materials.

Prerequisite:

- The fabric edges are finished.
- > Fit the Blindstitch Foot #5.
- > Tap «Practical Stitches».
- > Select Blind Stitch No. 9.
- > Fold the fabric back over the right side of the fabric to expose the overcast edge.
- > Place the fabric under the presser foot and move the folded edge against the metal guide on the presser foot.
- > Guide the folded edge evenly along the metal guide of the presser foot to sew the stitches evenly deep.
 - Make sure that the needle only pierces the edge of the fold.



- > After sewing about 10 cm, check both sides of the fabric and adjust the width again if necessary.



6.19 Sewing Visible Hems

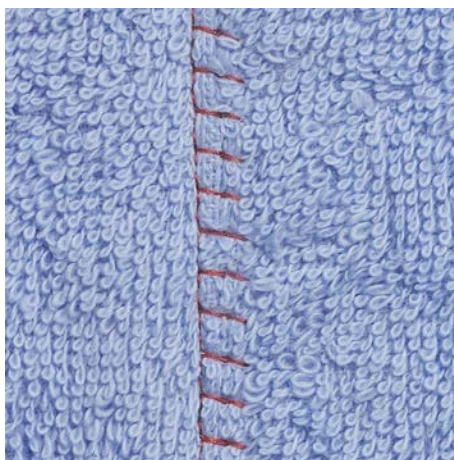


The visible hem is particularly suitable for elastic seams in tricot made of cotton, wool, synthetic and mixed fibers.

- > Fit the Reverse Pattern Foot #1C/1D.
- > Tap «Practical Stitches».
- > Select Tricot Stitch No. 14.
- > Iron the hem and baste if necessary.
- > Reduce the presser foot pressure if necessary.
- > Sew the hem in the desired depth on the right side of the fabric.
- > Trim off the remaining fabric on the wrong side of the fabric.



6.20 Sewing Flat Joining Seams



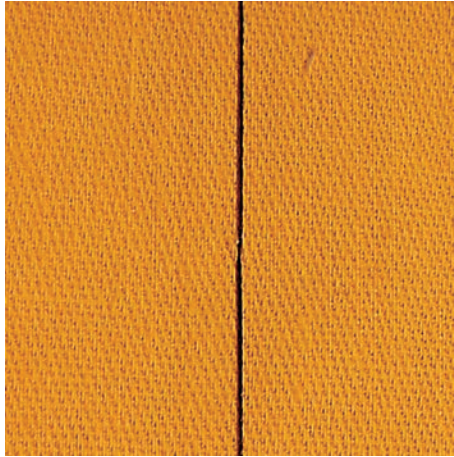
The flat joining seam is especially suitable for long-pile or thick materials such as terrycloth, felt or leather.

- > Fit the Reverse Pattern Foot #1C.



- > Tap «Practical Stitches».
- > Select Stretch Overlock No. 13.
- > Overlap the fabric edges.
- > Sew along the fabric edge.
- > To get a very flat, durable seam, make sure the needle stitches right over the top edge of the fabric into the bottom fabric.

6.21 Sewing basting stitches



When sewing basting stitches, it is recommended to use a fine darning thread. This is easier to remove. With the Basting Stitch No. 21, every fourth stitch is sewn. The longest stitch comes up to 24 mm when a stitch length of 6 mm is selected. The recommended stitch length is 3.5 – 5 mm. The Basting Stitch is suitable for sewing projects where a very long stitch length is required.



- > Fit the Reverse Pattern Foot #1C/1D.
- > Tap «Practical Stitches».
- > Select Basting stitch No. 21.
- > Select the stitch length.
- > Pin the fabric layers at a right angle to basting direction to prevent the layers from slipping.
- > Sew 3 – 4 securing stitches at the start and at the end.



7 Decorative Stitches

7.1 Overview Decorative Stitches

Easier or more difficult decorative stitches come into their own depending on the type of fabric.

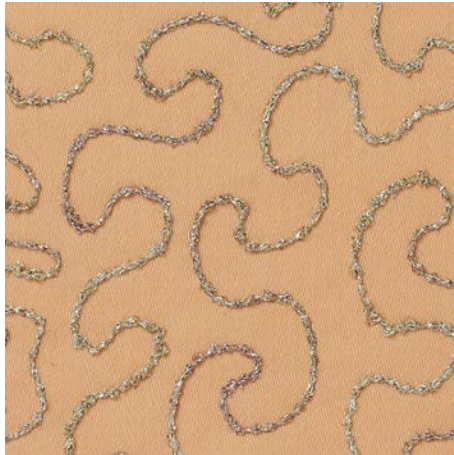
- Decorative stitches which are programmed with simple straight stitches are particularly appropriate for lightweight materials, e. g. Decorative StitchNo. 101.
- Decorative stitches which are programmed with triple straight stitches or with a few satin stitches are particularly appropriate for medium-weight materials, e. g. Decorative StitchNo. 107.
- Decorative stitches which are programmed with satin stitches are particularly appropriate for heavyweight materials, e. g. Decorative Stitch No. 401.

For a perfect stitch formation it is of advantage to use the same thread color for upper and bobbin thread and a stabilizer. With pile or long-pile materials it is recommended to use an additional, water-soluble stabilizer on the right side which can be easily removed after sewing.



Decorative stitch	Category	Name
	Category 100	Natural stitches
	Category 300	Cross stitches
	Category 400	Satin stitches
	Category 600	Geometric stitches
	Category 700	Heirloom stitches
	Category 900	Novelty stitches
	Category 1700	International
	Category 2000	Seasons
	Category 2200	Hobbies and sport

7.2 Bobbin-Play



The bobbin can be filled with different thread material. For free-motion stitching to add texture. This method is similar to "normal" free-motion sewing, but is done on the **wrong** side of the fabric.

Reinforce the area to be sewn with embroidery stabilizer. The design can be drawn on the wrong side of the fabric. You can also draw the design on the front side of the fabric. The lines can be followed with a freely guided straight stitch using polyester, cotton or rayon thread. The rows of stitching are visible on the wrong side of the fabric, and they serve as guidelines for the bobbin-thread sewing.

The BSR function can be used for bobbin-thread sewing. We recommend guiding your project evenly under the needle at a consistent speed, following the lines of the design. The stabilizer must be removed after sewing.

Sew a sample first to check what the result looks like on the wrong side of the fabric.

Not all decorative stitches are suitable for this technique. Simple decorative stitches provide best results. Avoid compact stitch types and satin stitches.

NOTICE

Inappropriate bobbin case is used

Damage of the bobbin case.

> Use the special bobbinwork case (optional accessory).



> Fit the Open Embroidery Foot #20C/20D.

> Tap «Decorative Stitches».

> Select an appropriate decorative stitch.

> Turn the «Upper Multifunction Knob» and the «Lower Multi-function Knob» to set the stitch length and stitch width so that a beautiful stitch formation can be achieved even when sewing with thick thread.



> Tap «i-Dialog».



> Tap «Long stitch».

– Every second stitch is sewn.



> To adjust the upper thread tension, tap «Upper Thread Tension».

7.3 Altering the stitch density

With certain decorative stitches (e. g. No. 401) the stitch density can be altered. If the stitch density is increased, the stitch distance is enlarged. If the stitch density is decreased, the stitch distance is shortened. The programmed length of the stitch pattern is not affected.

> Select the decorative stitch.



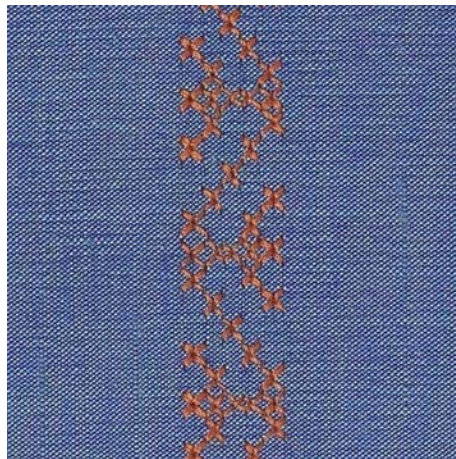
> Tap «i-Dialog».



> Tap «Altering the Pattern Length/Stitch Density».
> Set the stitch density (1).



7.4 Sewing Cross Stitches



Cross stitch embroidery is a traditional technique and an addition to the other decorative stitches. If the cross stitches are sewn on fabrics with a linen structure, they look as if they were hand-stitched. When cross stitches are sewn with embroidery yarn, the stitch pattern appears fuller. Cross stitches are particularly used for home furnishing, trimmings on garments and embellishing in general. As every following line refers to the first row, it is important to stitch the first row in a straight line.

- > Fit the Reverse Pattern Foot #1C/1D or Open Embroidery Foot #20C/20D.
- > Select a cross stitch of the Category 300 and combine it as desired.
- > Stitch the first row using the seam guide to sew a straight line.
- > Stitch the second row next to the first at a distance of one presser foot's width or using the seam guide.




7.5 Pintucks



Pintucks



Pintucks are narrow stitched folds, which are normally sewn on the fabric before cutting out the pieces for the garment or the sewing project. They are suitable for embellishing or in combination with other heirloom embroidery techniques. The use of Pintuck Feet can simplify this technique considerably. The technique reduces the size of the fabric piece. It is always advisable to plan in sufficient fabric.

Overview Pintuck Feet

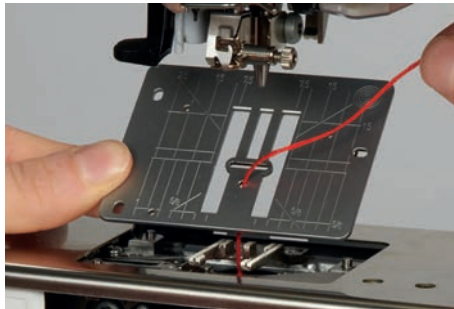
Pintuck Foot	Number	Description
	# 30 (optional accessory)	3 grooves For heavy-weight fabrics. In combination with the 4 mm twin needle
	# 31 (optional accessory)	5 grooves For heavy to medium-weight fabrics. In combination with the 3 mm twin needle
	# 32 (optional accessory)	7 grooves For light to medium-weight fabrics. In combination with the 2 mm twin needle

Pintuck Foot	Number	Description
	# 33 (optional accessory)	9 grooves For very light fabrics (without extra cord). In combination with the 1 or 1.6 mm twin needle
	# 46C (optional accessory)	5 grooves In combination with the 1.6 – 2.5 mm twin needle For very light to medium-weight fabrics.

Working with Cord

The pintucks look more distinctive and relief-like when they are sewn with a supplementary cord. Choose a cord that fits well into the grooves of the respective foot. The cord must be colorfast and shrink-proof.

- > Switch off the machine.
- > Remove the needle.
- > Remove the presser foot.
- > Remove the stitch plate.
- > Open the hook cover.
- > Pull the cord through the hook opening from the bottom and through the opening of the stitch plate.
- > Replace the stitch plate.
- > Close the hook cover.
- > Make sure that the cord slides through the thread slot of the bobbin cover.



- > Place the spool on the knee lifter.



- > Check that the cord runs smoothly.
- > If the thread doesn't glide smoothly at the hook cover, leave the hook cover open.

- > If the hook cover is opened, deactivate the lower thread indicator in the Setup Program.
 - The cord lies on the wrong side of the material and is hold/sewn over by the bobbin thread.

Sewing Pintucks

- > Insert the corresponding twin needle.
- > Threading the double needle.
- > Thread-up command.
- > Sewing the first pintuck.
- > Place the first pintuck in one of the side grooves in the presser foot.
- > Sew additional pintucks parallel.



8 Alphabets

8.1 Overview Alphabet

Block- outline, script, quilt and comic writing, as well as Cyrillic and Cyrillic script can be sewn in two different sizes. Block- outline, script, quilt and comic writing, as well as Cyrillic and Cyrillic script can also be sewn in small letters.

For a perfect stitch formation, it is recommended to use the same thread color for upper and bobbin threads. The fabric can be reinforced with embroidery stabilizer on the wrong side. When working with pile or napped fabrics, e.g. toweling, use an additional, water-soluble stabilizer on the right side of the fabric.



Stitch Pattern	Name
ABCabc	Block alphabet
ABCabc	Double-Block
ABCabc	Quilting text
<i>ABCabc</i>	Script (Italics)
ABCabc	Comic lettering
АБВабв	Cyrillic
<i>АБВ абв</i>	Cyrillic script
あいう	Hiragana
アイウ	Katakana

8.2 Creating Lettering



Sewing a test sample with the thread, the actual fabric and stabilizer you intend to use is recommended. Make sure that the fabric is fed evenly and lightly, ensuring that it cannot push against or catch on anything. The fabric shouldn't be pulled, pushed or held back.







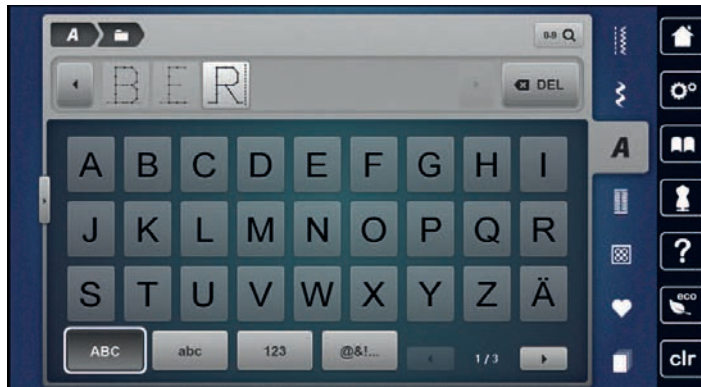
- > Tap «Alphabets».
- > Select the font.



- > To create a combination, tap «Combination Mode/Single Mode».
- > To open the extended Enter Mode, tap «Increasing/Decreasing the Display Size» (1).



- > Select the letters.
-  > To use upper-case letters, tap «Upper Case Characters» (standard setting).
-  > To use lower-case letters, tap «Lower Case Characters».
-  > To use figures and mathematical symbols, tap «Numbers and Mathematical Characters».
-  > To use special characters, tap «Special Characters».



- > To delete individual syllables of the entered text, tap «Deleting».
- > To close the extended Enter Mode, tap «Increasing/Decreasing the Display Size» again.

8.3 Altering font size

Block, Double block, Script and Comic alphabets as well as Cyrillic can also be downsized in the Single Mode.



- > Tap «Alphabets».
- > Select the font.
- > Select the letters.



- > Tap «i-Dialog».













- > To reduce the font size, tap «Alter Font Size».
- > To scale up the font size to 9 mm, tap «Alter Font Size» again.


9 Buttonholes

9.1 Overview Buttonholes

To be able to create the right buttonhole for every button, every purpose and also for every garment, the BERNINA 770 QE PLUS comes with an extensive collection of buttonholes. The corresponding button can be sewn on automatically. Eyelets can also be sewn.



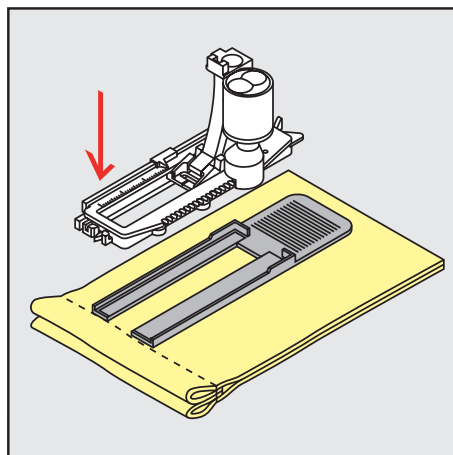
Stitch patterns	Stitch number	Name	Description
	51	Standard Buttonhole	For light to medium-weight fabrics. e.g. blouses, dresses and bed linen.
	52	Narrow Standard Buttonhole	For light to medium-weight fabrics, e.g. blouses, dresses, children's and baby clothes, crafts.
	53	Stretch Buttonhole	For all elastic fabrics.
	54	Round Buttonhole with Normal Bartack	For medium-weight to heavy fabrics. e.g. dresses, jackets, coats and rainwear.
	55	Round Buttonhole with Horizontal Bartack	For medium-weight to heavy fabrics, with a reinforced bar, e.g. dresses, jackets, coats and rainwear.
	56	Keyhole Buttonhole	For heavy, non-stretch fabrics, e.g. jackets, coats and leisurewear.
	57	Keyhole Buttonhole with Pointed Bartack	For stronger, non-stretch fabrics, e.g. jackets, coats, jeans and leisurewear.
	58	Keyhole Buttonhole with Horizontal Bartack	For strong, non-stretch fabrics, e.g. jackets, coats and leisurewear.
	59	Straight Stitch Buttonhole	For staystitching and reinforcing buttonholes and as button hole edging, especially for buttonholes in leather and imitation leather.
	60	Button Sew-on Program	Sews buttons with 2 or 4 holes.

	61	Eyelet with Small Zigzag	Openings for cords or narrow ribbons and for decorative work.
	62	Eyelet with Straight Stitch	Openings for cords or narrow ribbons and for decorative work.
	63	Heirloom Buttonhole	For handlook stitching effects on clothes and handicrafts on light to medium-weight fabrics.
	64	Double-rounded Buttonhole	For medium-weight to heavy fabrics made from different fabrics.
	65	Double-rounded Heirloom Buttonhole	For light to medium-weight woven fabrics, e.g. blouses, dresses and bedlinen.
	67	Round Buttonhole with Bartack	For medium-weight woven fabrics, e.g. blouses, dresses and jackets.
	68	Decorative keyhole buttonhole with horizontal bartack	For stronger, non-stretch fabrics, e.g. jackets, coats and leisurewear.
	69	Decorative Buttonhole with Double Pointed Bartack	For decorative buttonholes in firmer, non-elastic fabrics.
	70	Decorative stretch buttonhole	For decorative buttonholes in light to medium-weight knitted fabrics.

9.2 Making Use of the Height Compensation Tool

When a buttonhole is to be sewn at right angles to the project edge, it is recommend to use the height compensation plates (optional accessory).

- > Place the plates from the back between the sewing project and the bottom of the slide to the thick part of the sewing project.

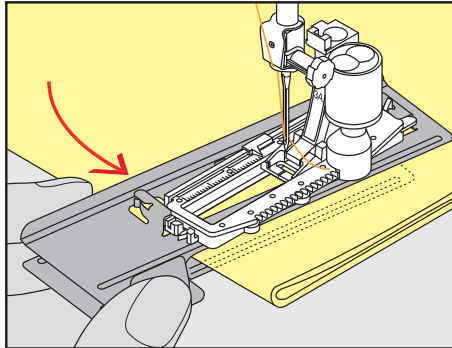


- > Lower the presser foot.

9.3 Using the Compensation Plate

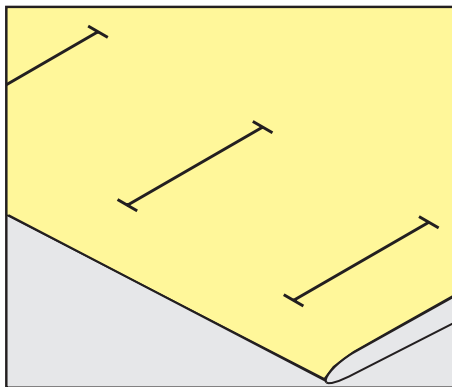
For sewing a buttonhole in problematic fabrics, it is recommended to use the Height Compensation Tool (optional accessory). The Height Compensation Tool can be used in combination with the Buttonhole Foot with Slide #3A.

- > Insert the compensation plate carefully from the side.

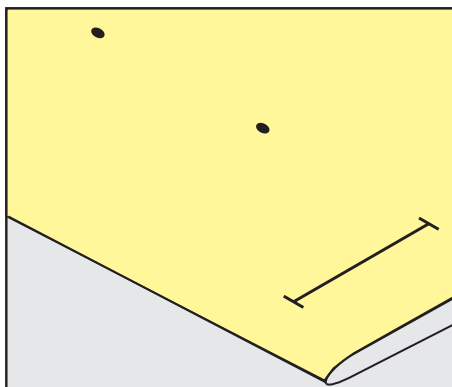


9.4 Marking Buttonholes

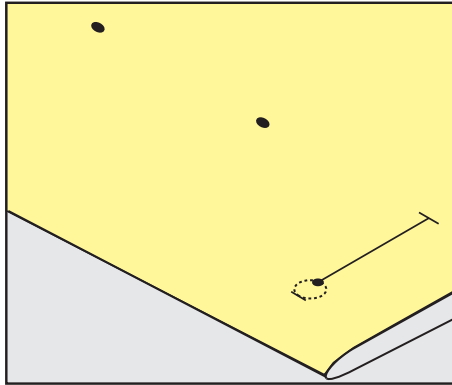
- > For the buttonholes to be sewn manually, mark the position and the length on the fabric using chalk or a water-soluble pen.



- > For the buttonholes to be sewn automatically, mark the complete length of 1 buttonhole on the fabric using chalk or a water-soluble pen. For any subsequent buttonholes mark the starting point.



- > For keyhole and round buttonholes mark the length of the bead with chalk or a water-soluble pen on the fabric. For any subsequent buttonholes mark the starting point. The length of the keyhole is sewn additionally.



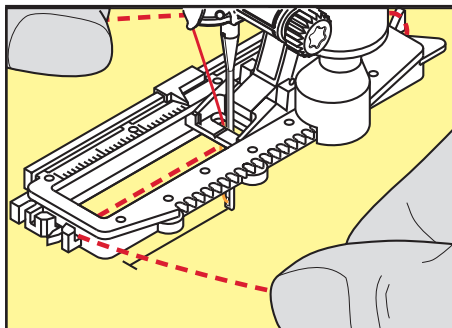
9.5 Cord

Using Cord with the Buttonhole Foot with Slide #3A

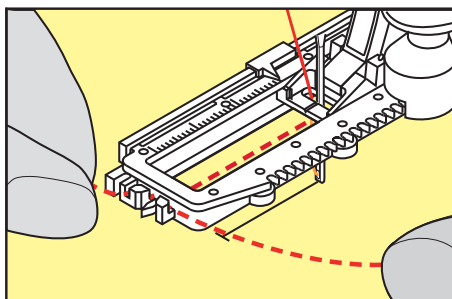
The additional cord reinforces and embellishes the buttonhole and is particularly suitable for the Buttonhole No. 51. Ideal cords are Perle cotton No. 8, strong hand-sewing thread and fine crochet yarn. It is recommended to not hold the cord while sewing.

Prerequisite:

- The Buttonhole Foot with Slide #3A is fitted and raised.
- > Insert the needle at the beginning of the buttonhole.
- > Guide the cord on the right side under the Buttonhole Foot with Slide.
- > Hook the cord over the pin at the back of the Buttonhole Foot with Slide.

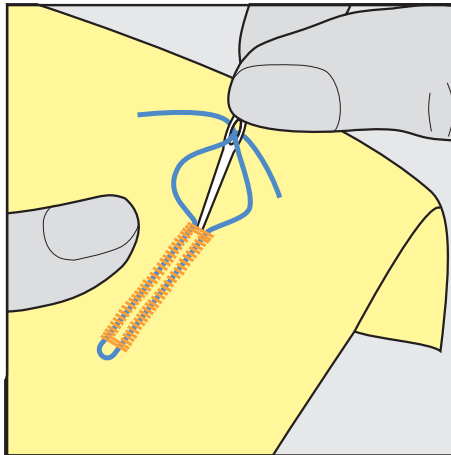


- > Pull the cord on the left side under the Buttonhole Foot with Slide to the front.



- > Pull the cord ends into the slits.
- > Lower the Buttonhole Foot with Slide.
- > Sew the buttonhole in the usual manner.
- > Pull the cord loop until the loop disappears in the bartack.

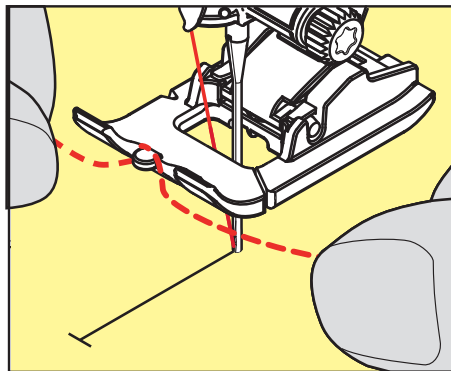
- > Pull the ends of the cord through to the wrong side of the fabric (using a hand sewing needle) and knot or secure them with stitches.



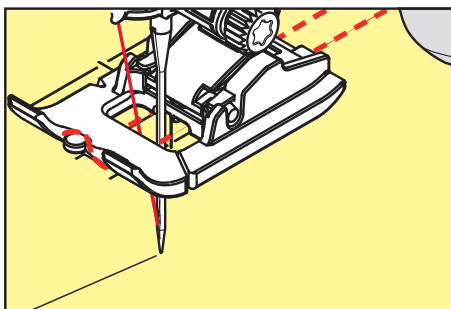
Using cord with the Buttonhole Foot #3C

Prerequisite:

- The Buttonhole Foot #3C is fitted and raised.
- > Insert the needle at the beginning of the buttonhole.
- > Hook the cord over the center pin at the front of the Buttonhole Foot.

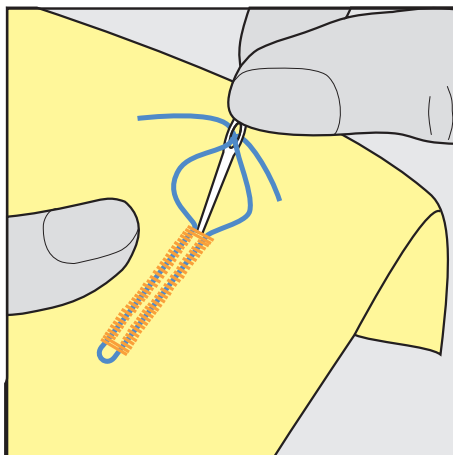


- > Pull both cords ends under the Buttonhole Foot to the back and place each a cord into a groove of the sole.



- > Lower the Buttonhole Foot.
- > Sew the buttonhole in the usual manner.
- > Pull the cord loop until the loop disappears in the bartack.

- > Pull the cord ends with the sewing needle to the back and knot or secure them.



9.6 Sewing a Test Sample

Always sew a test sample of the buttonhole on the same fabric: It is recommended to use the same stabilizer and to select the same buttonhole. The test sample should also be sewn in the respective direction. By sewing a test sample the settings can be adjusted until the sewing result is satisfying.

It is worth underlaying the buttonholes with the Straight Stitch Buttonhole No. 59 when working with soft loosely woven materials and for buttonholes which are severely strained. This is also recommended to reinforce buttonholes in leather, vinyl or felt.

Alterations of the Balance when sewing a manual standard buttonhole as well as the Keyhole and the Round Buttonhole affect both beads in the same way. With the manual keyhole or round buttonhole, the alterations affect both sides in the opposite way.

If the Stitch Counter function is used, and alterations are made concerning the Balance, the alterations affect both buttonhole beads differently.



- > Tap «Buttonholes».
- > Select the buttonhole.
- > Select and fit the desired presser foot.
- > Place the fabric under the presser foot and lower the presser foot.
- > Press the foot control carefully and start sewing. Guide the fabric slightly.
- > Check the Balance while sewing and adjust if necessary.
- > Check the test sample and make further amendments if necessary.

9.7 Determining the Buttonhole Slit Width

The width of the buttonhole slit can be adjusted between 0.1 – 2.0 mm before sewing.



- > Tap «Buttonholes».
- > Select the buttonhole.



- > Tap «i-Dialog».



- > Tap «Buttonhole Slit Width».
- > To adjust the desired width of the buttonhole slit, turn the Upper Multi-function Knob or the «Lower Multi-function Knob».

9.8 Determining the buttonhole length with the Buttonhole Foot with Slide #3A



The button can be placed in the yellow circle in the left section of the display. The yellow circle can be enlarged or downsized by turning the «Upper/Lower Multifunction knobs» and the diameter of the button can be determined in this way.

Additionally to the diameter of the button, 2 mm are added automatically for the buttonhole length. If the diameter of the button is 14 mm, the buttonhole length is calculated 16 mm.

Prerequisite:

- The Buttonhole Foot with Slide #3A is fitted.



- > Tap «Buttonholes».
- > Select the buttonhole.



- > Tap «i-Dialog».



- > Tap «Direct Entry Buttonhole Length».
- > Turn the «Upper Multi-function knob» or the «Lower Multi-function knob» to adjust the buttonhole length.

9.9 Determining the buttonhole length with Buttonhole Foot #3C

When the Buttonhole Foot #3C is used, the buttonhole length must be determined via the function Stitch Counter. The stitch counter function is suitable for all types of buttonholes. The left buttonhole bead is sewn forward, the right buttonhole bead is sewn in reverse. If alterations are made to the balance, the stitch counter function has to be saved for every buttonhole separately.

Prerequisite:

- The Buttonhole Foot #3C is fitted.



- > Tap «Buttonholes».
- > Select the buttonhole.



- > Tap «i-Dialog».

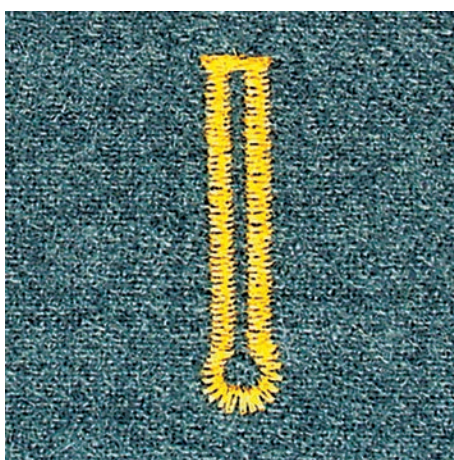
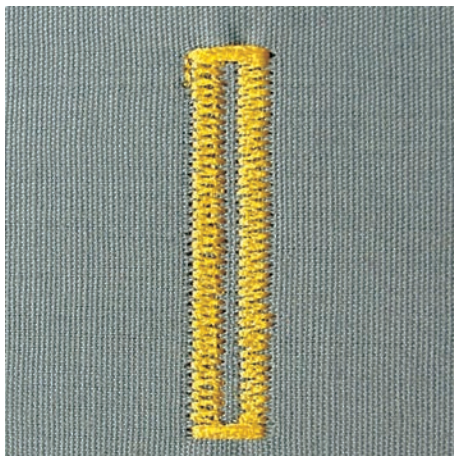


- > Tap «Programming the Length via the Stitch Counter».
- > Sew the desired length of the buttonhole.
- > Stop the machine.



- > The machine sews the lower bartack and the second bead in reverse when the button «Quick Reverse» is pushed.
- > Stop the machine at the height of the first stitch.
- > The machine sews the upper bartack and the securing stitches when the button «Quick Reverse» is pushed again.
 - The length of the buttonhole remains saved and every subsequent buttonhole is sewn identically until the machine is switched off.

9.10 Sewing a buttonhole automatically



When the Buttonhole Foot with Slide #3A is used, the length of the buttonhole is measured automatically by the lens on the presser foot. The buttonhole will be exactly duplicated and the machine switches to the next step automatically when the maximum length is reached. The Buttonhole Foot with Slide #3A is suitable for buttonholes at a length of 4 – 31 mm, depending on the buttonhole type. The Buttonhole Foot with Slide #3A must lie perfectly flat on the fabric so that the length can be measured accurately. Programmed buttonholes are the same length and of the same nice look.

Prerequisite:

- The Buttonhole Foot with Slide #3A is fitted.



- > Tap «Buttonholes».
- > Select the buttonhole No. 51 – 59, No. 63 – 65, or No. 67 – 70.
- > Sew the required length of the buttonhole.



- > To program the length, push the button «Quick Reverse».



- > Push the button «Start/Stop» or press the foot control.
 - The machine finishes the buttonhole automatically. All subsequent buttonholes are sewn at the same length.

9.11 Programming the Heirloom Buttonhole

Prerequisite:

- The Buttonhole Foot with Slide #3A is fitted.



- > Tap «Buttonholes».
- > Select Heirloom Buttonhole No. 63.
- > Sew the desired length of the buttonhole.

- > To program the length, push the button «Quick Reverse».
 - The machine finishes the buttonhole automatically. All subsequent buttonholes are sewn at the same length.

9.12 Sewing the manual 7-step buttonhole with the Buttonhole Foot #3C

The length of the buttonhole is determined manually when sewing. The bartack, eye and securing stitches are preprogrammed. The individual steps can also be selected by scrolling using the arrow icons or by pressing the button «Quick Reverse».

Prerequisite:

- The Buttonhole Foot #3C is fitted.



- > Tap «Buttonholes».
- > Select Standard Buttonhole No. 51.



- > Tap «i-Dialog».



- > Tap «Manual Length Adjustment».
 - Step 1 is activated in the display to start the buttonhole.
- > Sew the desired length of the buttonhole.
 - Step 2 is activated.



- > Stop when the required length of the buttonhole or the length marking is reached.
- > Step 3 appears by tapping «Scroll Down».
 - The machine sews straight stitches in reverse.
- > Stop at the height of the first stitch at the start of the buttonhole.
- > Step 4 appears by tapping «Scroll Down».
 - The machine sews the upper bartack and stops automatically.
- > Step 5 appears by tapping «Scroll Down».
 - The machine sews the second bead.
- > Stop the machine at the level of the last stitch of the first bead.
- > Step 6 appears by tapping «Scroll Down».
 - The machine sews the lower bartack and stops automatically.
- > Step 7 appears by tapping «Scroll Down».
 - The machine secures and stops automatically.

9.13 Sewing the Manual 5-step Buttonhole with the Buttonhole Foot #3C

The length of the buttonhole is determined manually when sewing. The bartack, eye and securing stitches are preprogrammed. The individual steps can also be selected by scrolling using the arrow icons or by pressing the button «Quick Reverse».

Prerequisite:

- The Buttonhole Foot #3C is fitted.

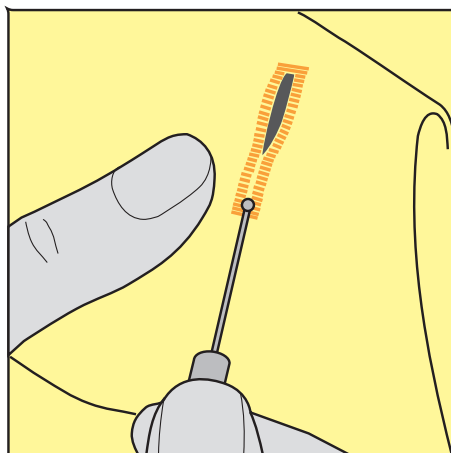
- > Tap «Buttonholes».
- > Select Round Buttonhole with Normal Bartack No. 54.
- > Tap «i-Dialog».
- > Tap «Manual Length Adjustment».
 - Step 1 is activated in the display to start the buttonhole.
- > Sew the desired length of the buttonhole.
 - Step 2 is activated.



- > Stop when the required length of the bead or the length marking is reached.
- > Step 3 appears by tapping «Scroll Down».
- > The machine sews the curve or eye and stops automatically.
- > Step 4 appears by tapping «Scroll Down».
 - The machine sews the second bead in reverse.
- > Stop the machine at the level of the first stitch where the buttonhole begins.
- > Step 5 appears by tapping «Scroll Down».
 - The machine sews the upper bartack and secures automatically.

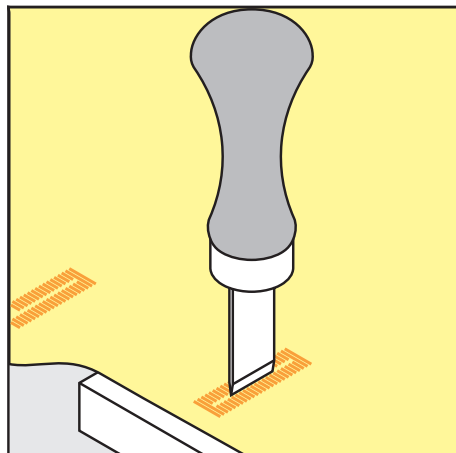
9.14 Cutting the Buttonhole Open with the Seam Ripper

- > Place a pin in each end of the buttonhole to avoid accidental cutting into ends of buttonhole.
- > Cut the buttonhole from both ends to the middle.



9.15 Cutting Open Buttonholes with the Buttonhole Cutter (Optional Accessory)

- > Place the fabric on an appropriate wood.



- > Position the cutter in the center of the buttonhole.
- > Press down on the cutter with your hand.

9.16 Sewing on a Button

The Button sew-on Program can be used to sew on buttons with two or four holes, press studs or snap fasteners.

Recommended sewing program: Button Sew-on Program No. 60

Recommended presser foot : Button Sew-On Foot #18

Alternative presser feet:

- Reverse Pattern Foot #1/1C
- Darning Foot #9
- Reverse Pattern Foot with Clear Sole #34/34C

Adjusting the Thread Shank

For buttons on thicker fabrics, increase the thread shank = the distance between the button and the fabric. Buttons sewn on thin fabrics or buttons for decorative purposes only are stitched without a «thread shank».

NOTICE! The adjustment of the thread shank is only possible when using the Button Sew-On Foot #18.

- > Loosen the screw on the back of the presser foot.
- > Push the bar upwards according to the thickness of the fabric.
- > Tighten the screw.

Sewing on a Button

Prerequisite:

- The shank length is adjusted according the fabric thickness.
- The Button Sew-On Foot #18 or an alternative presser foot is fitted.
- The fitted presser foot has been selected in the user interface.
- The feed dog is lowered.



- > Tap «Buttonholes».
- > Select Button Sew-on Program No. 60.
- > Turn the handwheel until the bobbin thread comes up.

- > **NOTICE! The Button sew-on program always starts above the left hole of the button.**
Position the button on the fabric. Place the button and the fabric beneath the needle so that the needle stitches into the left hole.
For buttons with 4 holes, sew the first front pair of holes first.
- > Lower the presser foot.
- > Perform the first stitches in the left hole via the handwheel.
- > Keep turning the handwheel until the needle changes to the right hole. In doing so, check whether the needle goes into the right hole. If necessary, adjust the stitch width by turning the upper Multifunction knob.
- > Hold the threads and push the foot control.
 - The machine sews on the button and stops automatically.
- > For increased stability, sew the Button sew-on Program again.
- > Cut the threads with the machine. Alternatively, pull the sewing projects from under the sewing machine and trim the threads by hand. Pull the upper thread to the wrong side of the fabric and knot it with the bobbin thread.

9.17 Sewing Eyelets



For increased stability sew the eyelet twice. Adjust stitch with the balance if necessary.

Prerequisite:

- The Reverse Pattern Foot #1C or the Open Embroidery Foot #20C is fitted.




- > Tap «Buttonholes».
- > Select Eyelet with Small Zigzag No. 61 or Eyelet with Straight Stitch No. 62.
- > Turn the, «Upper Multi-function Knob» or «Lower Multi-function Knob» to alter the size of the eyelet.
- > Sew the Eyelet Program.
 - The machine stops automatically at the end of the Eyelet Program.
- > Use an awl, punch pliers or a hole punch to open the eyelet.

10 Quilting

10.1 Overview Quilt Stitches



Stitch pattern	Stitch number	Name	Description
.....	No. 1301	Quilting, Securing Program	To secure at the sewing start and sewing end with short stitches forward.
.....	No. 1302	Quilting, Straight stitch	For machine quilting using a straight stitch with a 3 mm stitch length.
.....	No. 1303	Piecing stitch/Straight stitch	For sewing patchwork parts together using a straight stitch with a 2 mm stitch length.
.....	No. 1304 – No. 1308	Hand-look Quilt Stitch	For attaching an imitation of hand-look stitch with monofilament.
┌┐	No. 1309 – No. 1314	Blanket Stitch	For appliqués and sewing on ribbons.
⚡	No. 1317 – No. 1327 No. 1329 – No. 1330 No. 1339 – No. 1346 No. 1363 – No. 1371 No. 1373 – No. 1394	Decorative Quilt Stitch	For quilting, crazy patchwork, embellishing and finishing.
▬▬▬	No. 1315	Satin Stitch	For appliqué.
}	No. 1316	Narrow Blind Stitch	For hidden sewing of applications.
⦿	No. 1331	Stippling Stitch/ Stippling Quilt Stitch	For imitations of stippling stitch.

Stitch pattern	Stitch number	Name	Description
	No. 1332 – No. 1338	Feather Stitch	For quilting, crazy patchwork, embellishing and finishing.

10.2 Quilting, Securing Program

Prerequisite:

- The Reverse Pattern Foot #1C is fitted.

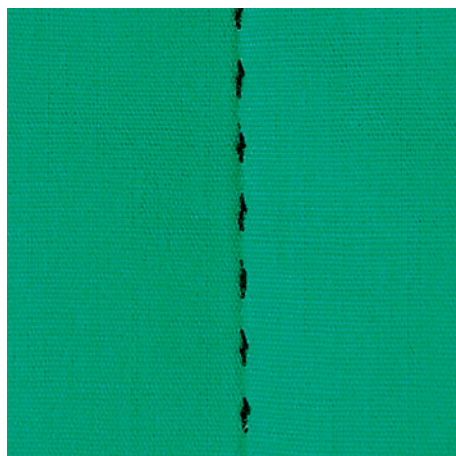


- > Tap «Quilt Stitches».
- > Select Quilting, Securing Program No. 1301.
- > Press the foot control.
 - The machine sews 6 stitches forward automatically when sewing is started.
- > Sew the seam at the desired length.



- > Push the button «Quick Reverse».
 - The machine sews 6 stitches forward automatically and stops automatically at the end of the Securing Program.

10.3 Sewing handlook quilt stitches



Handlook quilt stitches are suitable for all fabrics and sewing projects which should look hand sewn. It is recommended to use a monofilament thread as upper thread and an embroidery thread as bobbin thread. The sewing speed should be moderate to prevent the monofilament from breaking. If required, the upper thread tension and the Balance can be adjusted to the sewing project and the desired quilt stitch.

Prerequisite:

- The Reverse Pattern Foot #1C is fitted.



- > Tap «Quilt Stitches».
- > Select Hand-look Quilt Stitch No. 1304 No. 1308.
- > If necessary, adjust the upper thread tension and the balance to suit the sewing project and the desired quilt stitch.
- > To start the machine, press the foot control or push the button «Start/Stop».

10.4 Guiding the Quilt Work Freely



Freehand quilting and darning use the same principle of free movement. With stipple quilting, entire surfaces of the fabric are filled with quilt stitches. The single lines of stitching are rounded and never cross one another.



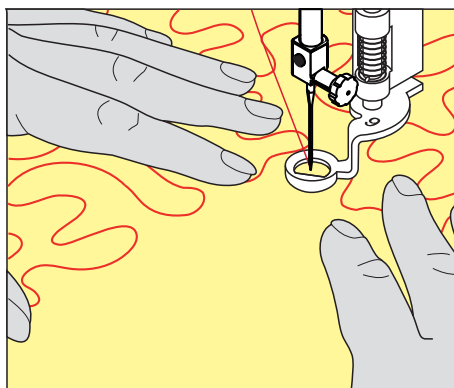
- Quilting gloves with rubber nubs make it easier to guide the fabric.
- For the best possible results use the High Thread Tension Bobbin Case (optional accessory).
- It is recommended to use the slide-on table and the Free Hand System.
- With free motion quilting, it is of advantage to quilt from the center outwards and to guide the fabric using smooth, round movements to form the design of your choice.

Prerequisite:

- The top layer, the batting and the backing are pinned together or basted.
- The feed dog is lowered.
- The Darning Foot #9 is fitted.



- > Tap «Practical Stitches».
- > Select Straight Stitch No. 1.
- > If required, adjust the upper thread tension.
- > To prevent the fabric from shifting, select the needle position down.
- > To start the machine, press the foot control or push the button «Start/Stop».
- > Hold both hands close to the presser foot like an embroidery hoop to guide the fabric. Make sure that the needle does not pierce the same place several times in a row.
- > To ensure a minimum stitch distance when quilting corners, reduce the embroidery speed.
- > If the thread is lying on top of the fabric, slow down the movement.
- > If there are knots on the wrong side of the fabric, move the fabric more quickly.



11 BERNINA Stitch Regulator (BSR)

The BERNINA Stitch regulator equalizes the stitch length which results of the free movement of the fabric while free-motion sewing - a sewing technique which grows more and more popular. When free-motion sewing with the BSR presser foot, every stitch is equally long and the stitch formation is perfectly regular.

As soon as the BSR presser foot is attached and the feed dog is lowered, the selection menu of the desired mode appears in the display of the machine. The BSR presser foot can be used with sewing straight stitch as well as zig zag.

The BSR presser foot reacts on the movement of the fabric and therefore controls the speed of the machine up to the highest possible speed. It can be said: The faster the movement of the material, the higher the speed of the machine.

If the fabric is moved too quickly, an acoustic signal sounds. The beeper can be activated or deactivated in the «BSR» display. The sound of the beeper can also be activated or deactivated in the Setup Program.

11.1 BSR Mode 1

The BSR function can be controlled via the foot control or the button «Start/Stop». Start the BSR mode. At the BSR presser foot a red light is on. By moving the fabric the machine accelerates. If the fabric isn't moved, securing in place is possible without pressing an additional button. When working via the foot control or when using the button «Start/Stop», the BSR mode doesn't stop automatically.

11.2 BSR Mode 2

The BSR function can be controlled via the foot control or the button «Start/Stop». The machine starts only when the foot control or the button «Start/Stop» is pressed and the fabric is moved simultaneously. Without moving the fabric, the BSR2 mode stops after 7 seconds. The red light goes off (only when working with the button «Start/Stop»). When working via the foot control, the red light doesn't go off.

11.3 BSR mode 3

BSR mode 3 is stitching mode. In basting mode, you can choose between two stitch lengths:

- SPI 2: Two stitches per inch
- SPI 4: Four stitches per inch

11.4 BSR Function with Straight Stitch No. 1

This function allows free-motion quilting with straight stitch and a pre-programmed stitch length up to 4 mm. The programmed stitch length is maintained within a certain speed, independent of the fabric movement.

11.5 BSR Function with Zigzag No. 2

The zig zag can be used e.g. for thread painting. The set stitch length will **not** be maintained when sewing the zig zag stitch, but the BSR function simplifies the application. Anwendung.

11.6 Sewing Preparations for Quilting

Attach the BSR presser foot

Prerequisite:

- The machine is switched off.

NOTICE

The Lens of the BSR Presser Foot is Dirty

The machine doesn't recognize the BSR presser foot.

> Clean the lens with a soft, slightly damp cloth.

> Change the presser foot.

- > Insert the cable of the BSR Foot into the connection (1).



- > Switch the machine on.
 - The BSR display opens and the BSR1 Mode is activated.

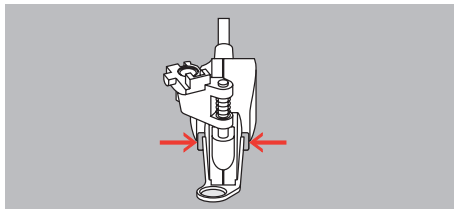
Changing the Presser Foot

NOTICE

The Lens of the BSR Presser Foot is Dirty

The machine doesn't recognize the BSR presser foot.

- > Clean the lens with a soft, slightly damp cloth.
-
- > Raise the needle.
 - > Raise the BSR foot.
 - > Switch off the machine.
 - > Remove the BSR foot from the machine.
 - > Press both push buttons at the BSR foot against each other.



- > Pull the presser foot sole out of the guide downwards.
- > Insert the new presser foot sole into the guide and push upwards until it clicks into place.
- > Attach the BSR presser foot.

11.7 Using the BSR Mode

The BSR function can either be operated via the foot control or via the button «Start/Stop».

Start via the Foot Control: The foot control must be pressed down while quilting is in progress. The machine keeps running in BSR Mode 1 until the foot control is released, even if the fabric is not moved.

If quilting in BSR Mode 2 is stopped, the machine sews another stitch depending on the needle position and stops with needle position up.

Prerequisite:

- The slide-on table has been fitted.
- The knee lifter is attached.



> Lower the feed dog.

> Select the desired BSR Mode.



> To lower the presser foot, push the button «Start/Stop» or press the foot control.

- > To start the BSR Mode, push the button «Start/Stop» again or press and hold the foot control again.
 - A red light is lit on the BSR Presser Foot.

- > Move the fabric to control the speed of the machine in the BSR Mode.
-  > To stop the BSR Mode, push the button «Start/Stop» again or release the foot control.
 - The BSR Mode stops and the red light at the presser foot goes off.
-  > To deactivate the BSR Mode and to quilt without automatic stitch lengths, tap «BSR Mode».





11.8 Securing Stitches


Securing in BSR1 Mode with the Button «Start/Stop»

Prerequisite:

- The BSR presser foot is fitted and connected to the machine.
- The BSR display opens and a BSR1 Mode is active.

- > Lower the feed dog.
- > Lower the presser foot.
-  > Push the button «Needle position Up/Down» 2x.
 - The bobbin thread is brought up.


- > Hold the upper and the bobbin thread.
-  > Push the button «Start/Stop».
 - Start the BSR Mode.

- > Sew 5 – 6 securing stitches.
-  > Push the button «Start/Stop».
 - The BSR Mode stops.
- > Cut the thread.

Securing in BSR2 Mode

Prerequisite:

- The BSR presser foot is fitted and connected to the machine.
- The BSR display opens and a BSR2 Mode is active.

- > Lower the presser foot.
-  > Push the button «Securing Stitches».
- > Press the foot control or push the button «Start/Stop».

By moving the fabric some short securing stitches are sewn, then the programmed stitch length is activated and the securing function is deactivated automatically.

11.9 Using the KickStart function

The KickStart function enables quilting without keeping the foot control pressed.

Prerequisite:

- The BSR Presser Foot is fitted and connected to the machine.
- The BSR display opens and a BSR Mode is active.



- > Tap «KickStart».
 - The KickStart display appears. The selected BSR Mode is displayed.
- > To start the machine, press the foot control **briefly** with your heel.
 - The machine starts sewing with the selected settings as soon as the fabric is moved.
- > To stop the machine, press the foot control briefly with your heel again.
 - The machine will stop, but the KickStart function will remain active.
- > To end the KickStart function, tap the screen or press the foot control at the front.
 - The BSR display appears.
 - The KickStart function will be deactivated.
 - The function programmed for the Back-kick will be active.

Please note

- While the KickStart function is active, the function programmed for Back-kick is deactivated. The Back-kick then only serves to start and stop the machine.
- The KickStart function will be ended immediately if the active monitoring function reports an error (e.g. thread breakage or bobbin empty).
- The KickStart function will be ended immediately if the foot control cable is unplugged.
- If there is no sewing in BSR Modes, the machine goes into Stand-by Mode after 7 seconds. Exit the Stand-by Mode by pressing the heel again.
- If no sewing is done for up to 60 seconds, the KickStart function is automatically terminated. The KickStart display disappears.

12 My BERNINA Embroidery

12.1 Overview Embroidery module





- 1 Embroidery arm
- 2 Coupling for securing the hoop

- 3 Guide rails for the machine
- 4 Connection to the machine



12.2 Supplied Accessories Embroidery Module

Overview Accessory Embroidery Module

Illustration	Name	Purpose
	Drop-shaped Embroidery Foot #26	For embroidering, darning and freehand quilting.
	Large Oval Embroidery Hoop	To embroider large embroidery designs or design combinations up to 145 x 255 mm (5.70 x 10.04 in). Template for precise fabric positioning included.
	Medium Embroidery Hoop	To embroider medium-sized embroidery designs up to 100 x 130 mm (3.94 x 5.12 in). Template for precise fabric positioning included.
	Small Embroidery Hoop	To embroider small embroidery motifs up to 72 x 50 mm (2.83 x 1.97 in). For free arm embroidering with closed sewing projects such as sleeves, trouser legs or socks. Including the template for precise fabric positioning.
	Embroidery Needle Assortment	For embroidering.
	Template Holder	To place and remove the template in or out of the embroidery hoop.
	Spool Net	For even thread unwinding with smooth threads from the thread spool, e.g. nylon, rayon, silk threads or metallic yarns.

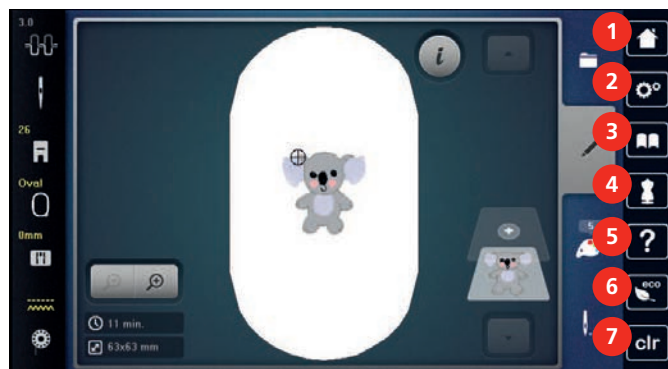
12.3 Overview User Interface

Overview functions/visual information



- | | | | |
|---|---|---|--------------------------|
| 1 | «Upper Thread Tension» | 5 | «Stitch Plate Selection» |
| 2 | «Needle Selection» | 6 | «Feed Dog Indicator» |
| 3 | «Presser Foot Indicator/Presser Foot Selection» | 7 | «Bobbin Thread» |
| 4 | «Hoop Indicator/Select Hoop» | | |

Overview System settings



- | | | | |
|---|-----------------------|---|------------------|
| 1 | «Home» | 5 | «Help» |
| 2 | «Setup Program» | 6 | «eco Mode» |
| 3 | «Tutorial» | 7 | «Clear Settings» |
| 4 | «Creative Consultant» | | |

(only available in Sewing Mode)

Overview Selection Menu Embroidery



- | | | | |
|---|-------------|---|---------------------|
| 1 | «Selection» | 3 | «Color Information» |
| 2 | «Edit» | 4 | «Embroidery» |

12.4 Important Embroidery Information

Upper Thread

A good quality thread (name-brand manufacturer) is essential for embroidery so that the embroidery is not affected negatively because of poor thread or thread breakage.

Embroidery is particularly effective if you use 40wt glossy rayon or polyester embroidery threads as upper threads. They are available in a wide range of colors for beautiful embroidery.

- Polyester with a brilliant sheen is a hard-wearing, colorfast thread and has a high tensile strength which is suitable for all types of embroidery.
- Rayon is a soft viscose fiber with a brilliant sheen and suitable for fine, delicate embroidery, or items that will not receive excessive wear and tear.
- Metallic thread is a light to medium-weight thread suitable for special effects in embroidery.
- When working with metallic threads, the automatic bobbin thread cutter should be deactivated. The other thread cutters shouldn't be used either because the knives are likely to wear off very quickly.
- When using metallic threads, the speed and the upper thread tension should be reduced.



Bobbin Thread

In most cases black or white bobbin thread is used for embroidering. When both sides should have the same look, it is recommended to use the same color for bobbin and upper thread.

- Bobbin Fill is an especially soft and light polyester thread which is suited to be used as bobbin thread. This special bobbin thread ensures a steady thread tension and an optimal intertwining of the upper and bobbin thread.
- Darning and embroidery threads are fine mercerized cotton threads which are suitable for embroidery on cotton.

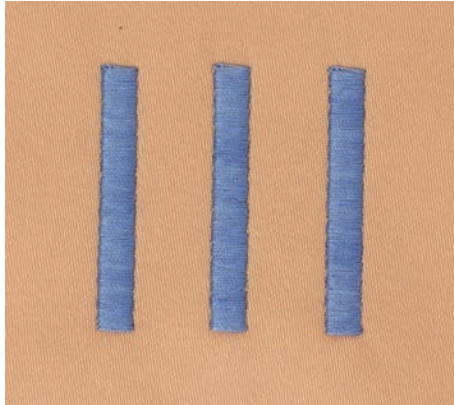


Choosing the Embroidery Design

Simple designs with a low stitch count are suitable for embroidery on fine material. Densely embroidered designs, e. g. embroidered designs with multiple color and embroidery direction changes, are suitable for medium and heavy-weight material.

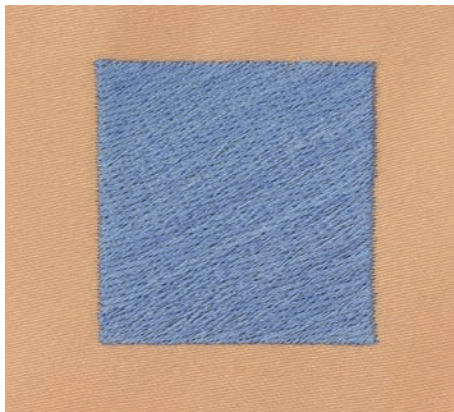
Satin or Leaf Stich

The needle moves left to right and vice versa. The result is a very dense, covering zig zag stitching to fill the shape. Satin stitching fills are ideal for narrow and small shapes. Satin stitching is, however, not suitable for larger areas, since wide stitches are too loose and do not cover the fabric properly. In addition there is the risk that with too long stitches the threads could catch on something which would damage the embroidery.



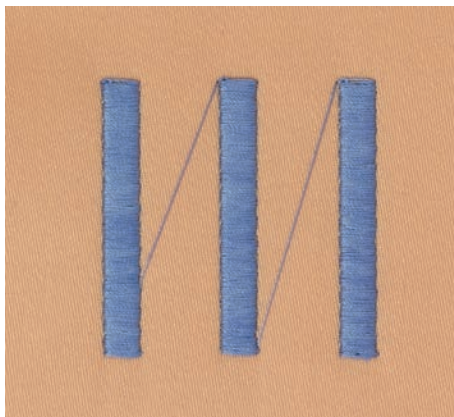
Step Stitch

Many short, equally long stitches are embroidered in offset rows closely next to each other which results in a densely filled area.



Connecting Stitches

Long stitches which are used to get from one part of the motif to the next. Before and after the connecting stitch securing stitches are sewn. Connecting stitches are trimmed.



13 Embroidery preparation

13.1 Attaching the Module

NOTICE

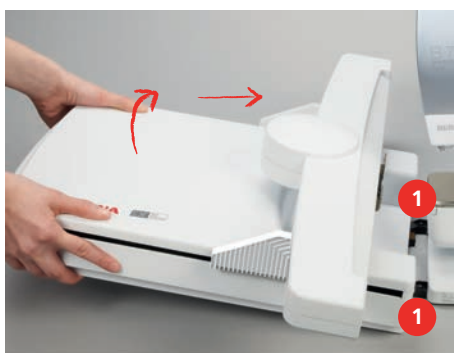
Transporting the Embroidery Module

Damage to the embroidery module connection and machine.

- > Remove the embroidery module before transporting the machine.

Prerequisite:

- Extension table must not be fitted.
- > Make sure that the module and the machine are placed on a stable, even surface.
- > Ensure that the embroidery arm can move freely.
- > Lift the embroidery module on the left side.
- > Carefully push the module from left to right into the embroidery module connection (1) of the machine.



- > To remove, lift the embroidery module on the left and carefully pull to the left.



13.2 Preparing the Machine

Lowering the feed dog

- > Push the button «Feed Dog Up/Down».



Selecting an embroidery motif

All embroidery motifs can either be embroidered as-is or they can be changed by using the various functions. You can find all embroidery motifs at the end of the instruction manual. Furthermore, embroidery motifs from the Personal Memory or from the BERNINA USB stick can be loaded.

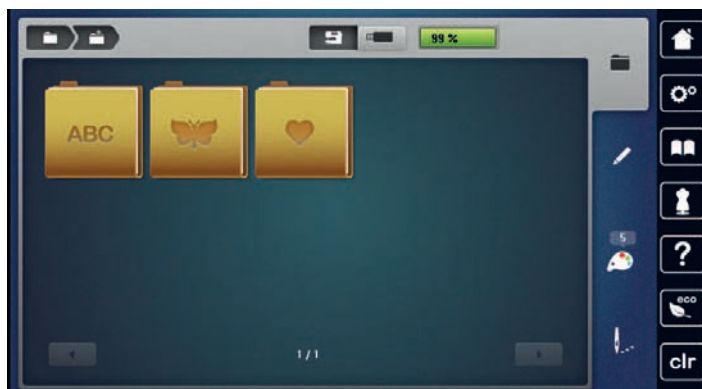


> Tap «Home».



> Tap «Embroidery Mode».

> Select an alphabet, an embroidery motif, a stitch pattern or a personal embroidery motif from one of the files.



13.3 Embroidery Foot

Attaching the embroidery foot

- > Raise the needle.
- > Raise the presser foot.
- > Switch off the machine.
- > Push the clamping lever up.
- > Remove the presser foot.
- > Insert the embroidery foot from below into the bracket.
- > Press the clamping lever down.



Selecting the Stitch Plate in the User Interface

After fitting the corresponding embroidery foot, it can be selected and saved on the machine. Moreover optional presser feet can be displayed which are available for the currently selected embroidery design.

- > Switch the machine on.
- > Select the embroidery design.



> Tap «Presser Foot Indicator/Presser Foot Selection».



> To display all suitable presser feet for the selected embroidery design, tap «Optional Presser Feet».
> Select the fitted embroidery foot.

13.4 Needle and Stitch Plate

Inserting the embroidery needle



Embroidery needles of the type 130/705 H-SUK provide a larger eye and are slightly rounded. This avoids thread abrasion when using Rayon- and cotton embroidery thread. Depending on the embroidery thread use a size No. 70-SUK to No. 90-SUK needle.

- > Raise the needle.
- > Switch off the machine.
- > Remove the fitted foot.
- > Loosen the fixing screw of the needle using the screwdriver gray Torx.



- > Pull the needle down.
- > Hold the new needle with the flat side to the back.
- > Insert the needle as far as it will go.
- > Tighten the needle clamp using the gray Torx screwdriver.

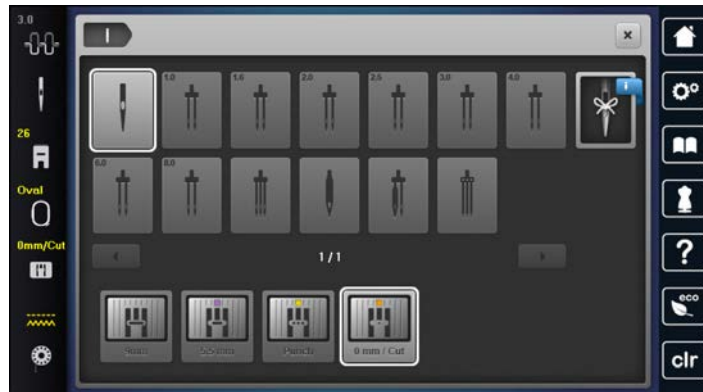
Selecting the embroidery needle in the User Interface

After changing the needle, you can check whether this can be used with the selected stitch plate.



> Tap «Needle Selection».

- > Select the fitted needle.



- If the selected needle is suitable in combination with the stitch plate, embroidering can be started.
- If the selected needle is not suitable in combination with the stitch plate, starting the machine is automatically blocked.

Selecting needle type and needle size

Convenient memory function: To prevent a loss of information, the needle type and the needle size can be saved additionally on the machine. The saved needle type and the saved needle size can be checked at any time.



- > Tap «Needle Selection».



- > Tap «Needle Information».



- > Select the needle type (1) of the fitted needle.
- > Select the needle type (2) of the fitted needle.

Attaching the stitch plate

The stitch plate (Straight and CutWork Stitch Plate) has a small hole in the needle area. The stitch formation (thread knotting of upper and bobbin thread) is thus optimized. This results in a more beautiful stitch appearance.

- > To lower the feed dog, push the button «Feed Dog Up/Down».



- > Switch off the machine.

- > Remove the needle.
- > Remove the presser foot.
- > At the marking on the upper right corner of the stitch plate, push the stitch plate downwards until it tips.



- > Remove the stitch plate.
- > Place the opening of the stitch plate (Straight and CutWork Stitch Plate) above the corresponding guide pins and press it down until it clicks into place.

Selecting the stitch plate in the User Interface

After changing the stitch plate, you can check whether this can be used with the selected needle.



- > Tap «Stitch Plate Selection».
- > Select the previously fitted stitch plate.



- If the selected stitch plate is suitable to be used in combination with the needle, sewing can begin.
- If the selected stitch plate is not suitable to be used in combination with the needle, an error message is displayed and starting the machine is automatically prevented.

Thread-up Command

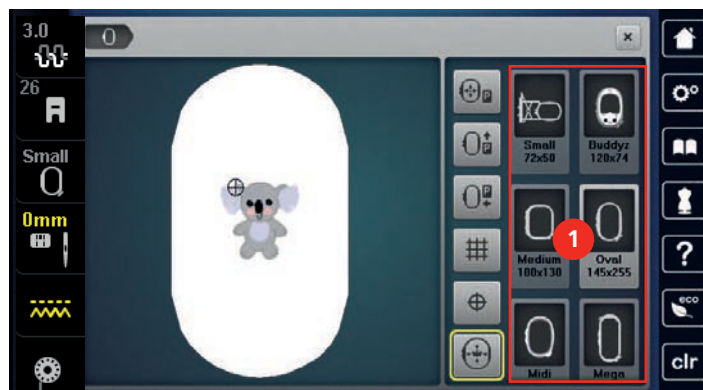
The machine must be ready for embroidery to bring up the bobbin thread. The bobbin thread can be brought up in one step for a manual knotting. If no securing stitches are wanted, it is recommended to deactivate the securing stitches in the Setup.



- > Hold the upper thread.
- > Push the button «Presser Foot Up/Down».
 - The bobbin thread is brought up automatically.

13.5 Embroidery Hoops

Overview Embroidery Hoop Selection



1 Hoop Selection

Selecting the Embroidery Hoop

The best embroidery result is achieved when the smallest possible embroidery hoop for the embroidery design is selected.

The embroidery design has a pre-set size which is displayed.

Prerequisite:

- The embroidery design is selected.



- > Tap «Hoop Indicator/Select Hoop».
 - The machine selects the optimal embroidery hoop according to the size of the embroidery design automatically. If the preset embroidery hoop is not available, another desired embroidery hoop can be selected. When an embroidery hoop is attached which does not correspond with the selected one, the attached hoop is considered active and the embroidery design area is displayed accordingly.
- > Select the desired embroidery hoop.

Tear-away Stabilizers

Using a stabilizer ensure more stability of the embroidery project. A tear-away stabilizer suits all woven and non-stretch materials. 1 – 2 layers can be used. Stabilizers are available in different weights. With larger areas to be embroidered the stabilizer will remain under the embroidery thread. The stabilizer is applied to the wrong side of the fabric with temporary adhesive spray. Carefully cut away excess stabilizer after embroidering.

Cut-away Stabilizers

Using a stabilizer ensure more stability of the embroidery project. A cut-away stabilizer suits all elastic materials. 1 – 2 layers can be used. Stabilizers are available in different weights. With larger areas to be embroidered the stabilizer will remain under the embroidery thread. The stabilizer is applied to the wrong side of the fabric with temporary adhesive spray. Carefully cut away excess stabilizer after embroidering.

Using Adhesive Spray

The application of spray adhesive is recommended for stretch and smooth materials and knitware. It prevents the fabric from losing shape and slipping. Appliqués can be exactly positioned with spray adhesive. The spray adhesive shouldn't be used near the machine to avoid contamination.

- > Use the spray adhesive carefully at a distance 25 – 30 cm (9 – 12 inch) when spraying the stabilizer.
- > Adhere the sprayed stabilizer to the wrong side of the fabric carefully, smoothing material so there are no puckers.
- > Position smaller parts such as pocket flaps or collars on the stabilizer.

- > To avoid the possibility of getting hoop marks when working with napped materials or fleece, don't hoop the parts but spray the stabilizer and hoop it.
- > Adhere the fabric to be embroidered.
- > Remove any adhesive residue before starting the machine.

Using Spray Starch

Spray starch is ideal for additional stiffening fine, loosely woven materials. Always use an additional stabilizer on the wrong side of the material.

- > Spray the area to be embroidered.
- > Let it dry or press gently with a warm iron if necessary.

Using Iron-on Interfacing

Iron-on interfacings are available in a variety of weights. It is recommended to use an iron-on interfacing which is easily removable from the basic fabric. An Iron-on interfacing suits all materials that are easily distorted like stretch fabric such as tricot and jersey.

- > Iron-on interfacings are ironed to the wrong side of the material using a warm iron.

Using Paper-backed Adhesive Stabilizer

Paper-backed adhesive stabilizers are intended to be used for fabrics such as jersey and silk as well as for embroidery projects which are not suited to be hooped in the embroidery hoop.

- > Place the stabilizer in the hoop, so that the paper side is up.
- > Use a pair of scissors to score the paper and remove paper in the hoop area.
- > Position the fabric to be embroidered on the stabilizer and press it on place.
- > Remove any adhesive residue before starting the machine.

Using Water-soluble Stabilizer



For lace embroidery it is recommended to hoop 1 - 3 layers of water-soluble stabilizer in the embroidery hoop. As the embroidery design is not embroidered on the fabric, only the thread embroidered design is left. The embroidery designs should be combined with short stitches otherwise the individual designs may fall out.

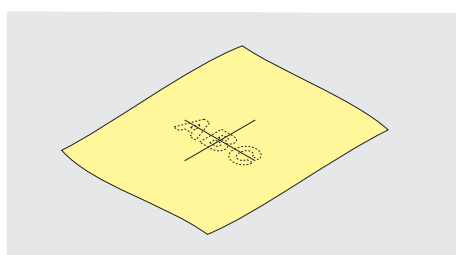
Water-soluble stabilizers are ideal for fine, sheer fabrics where other stabilizers may show through the embroidery stitches as well as for lace embroidery. The stabilizer dissolves in water. Water-soluble stabilizers are an ideal protection for looped pile fabrics preventing the loops from being damaged. It prevents threads from sinking into the material and keeps the fabric pile from poking through the embroidery.

- > Place the stabilizer on the underside of the material.
- > Use adhesive spray to adhere stabilizer if necessary.
- > For material with a pile, reinforce with additional, suitable stabilizer on the wrong side.
- > Place all the layers together into the embroidery hoop.
- > After dissolving, lay the motif down flat and let dry.

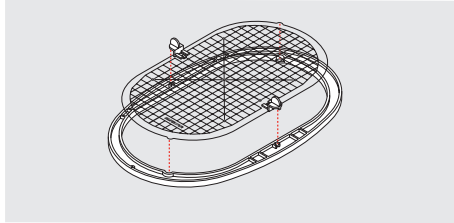
Preparing the Embroidery Hoop

The embroidery hoop consists of an outer and an inner hoop. There is a corresponding template for every hoop. The area to be embroidered is marked in 1 cm (0.39 inch) squares. The center and corner points are marked with holes. The required marks can be transferred to the material.

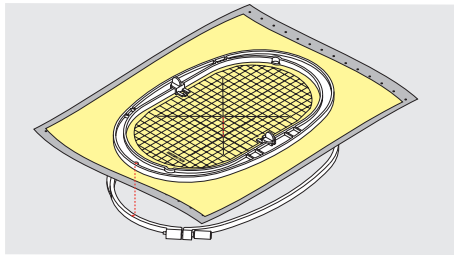
- > Mark the center of an embroidery design on the fabric, using a water-soluble pen.



- > Loosen the screw on the outer hoop.
- > Remove the inner hoop.
- > Make sure that the arrows marks of both hoops match.
- > Attach the template holder.
- > Place the template in the inner hoop, so the BERNINA logo is at the front edge at the arrow mark until it clicks into place.



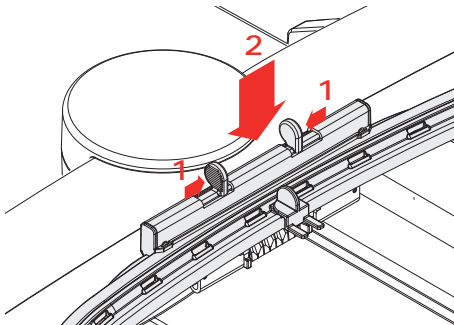
- > Place the fabric under the inner hoop.
- > Line up the marked center point on the center of the template.
- > Place the material and the inner hoop on the outer hoop, so that the arrow markings of both hoops are aligned.



- > Fit the hoops into each other so that the material does not move.
- > Hoop the fabric tautly in the embroidery hoop.
- > Tighten the screw.
- > Remove the template from the hoop by using the template holder.
- > To avoid scratches on the free arm, press the inner hoop into the outer hoop so that the inner hoop including the fabric protrudes downwards by up to 1 mm.

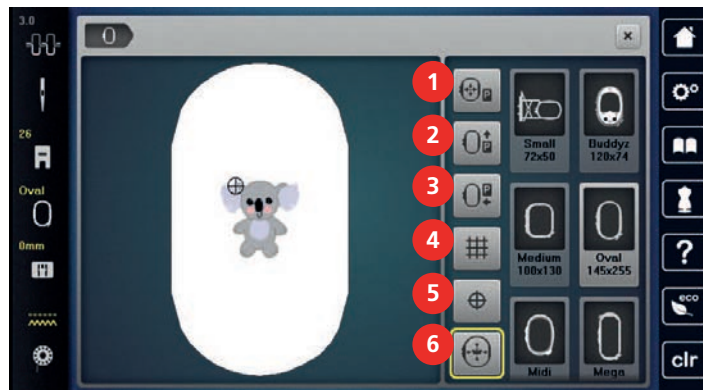
Attaching the Hoop

- > Raise the needle.
- > Raise the embroidery foot.
- > Hold the hoop with the right side of the fabric up with the attaching mechanism to the left.
- > Position the hoop below the embroidery foot.
- > Press both attaching mechanisms (1) of the hoop towards each other.
- > Position the embroidery hoop (2) above the bracket of the embroidery arm.
- > Press the hoop down until it clicks in position.
- > Release the attaching mechanism (1).



- > Press the attaching mechanisms of the hoop towards each other to remove the hoop.
- > Remove the hoop.




Overview Embroidery functions



- | | | | |
|---|---|---|-------------------------------|
| 1 | «Centering the Needle to the Embroidery Hoop» | 4 | «Grid On/Off» |
| 2 | «Move Hoop to the Back» | 5 | «Center of Embroidery Design» |
| 3 | «Move Hoop to the Left» | 6 | «Virtual Positioning» |




Centering the Needle to the Embroidery Hoop

Relocating the embroidery hoop facilitates threading when the needle is close to the embroidery hoop.

-  > Tap «Hoop Indicator/Select Hoop».
-  > Tap «Centering the Needle to the Embroidery Hoop».
- > Thread the upper thread.
-  > To move the hoop back to its previous position, push the button «Start/Stop».





Move Hoop to the Back

To facilitate changing the bobbin, it is recommended to move the hoop to the back before threading. This makes it easier to open the bobbin cover.

-  > Tap «Hoop Indicator/Select Hoop».
-  > Tap «Move Hoop to the Back».
- > Thread the bobbin thread. (see page 45)
-  > To move the hoop back to its previous position, push the button «Start/Stop». If necessary, pull back the upper thread.

Moving the Module for the Sewing Mode

The embroidery module can be positioned so that any sewing projects can be carried out even if the module is connected.

-  > Tap «Hoop Indicator/Select Hoop».
- > Remove the hoop.
-  > Tap «Move Hoop to the Left».
-  > Tap «Home».
-  > Tap «Sewing Mode».

Grid On/Off

When the center of the hoop and the grid are displayed, the embroidery design can be positioned more exactly.



> Tap «Hoop Indicator/Select Hoop».



> To show the hoop center on the display, tap «Grid On/Off».

> To show the grid lines, tap «Grid On/Off» again.

> To hide the hoop center and the grid lines, tap «Grid On/Off» again.

Locating the Center of the Embroidery Design

The embroidery hoop is positioned so that the needle is exactly above the center of the embroidery design or the motif begin.



> Tap «Hoop Indicator/Select Hoop».



> To position the hoop so that the needle is placed exactly over the center of the embroidery design, tap «Center of Embroidery Design».

> To position the hoop so that the needle is placed exactly over the motif start, tap «Center of Embroidery Design» again.

Virtual Positioning of the Embroidery Hoop

The embroidery hoop is automatically moved to the new position as soon as the embroidery design is repositioned. Therefore, the icon «Virtual Positioning» is activated automatically and outlined in yellow when an embroidery hoop is attached.

Prerequisite:

- The hoop is attached.



> Tap «Hoop Indicator/Select Hoop».



> To deactivate the automatic movement of the hoop after repositioning the embroidery design, tap «Virtual Positioning».

– The «Virtual Positioning» is not yellow-outlined.

> To activate the automatic movement of the hoop after repositioning the embroidery design, tap «Virtual Positioning» again.

14 Setup Program

14.1 Adjusting the Embroidery Settings in the Setup Program

Further information about this topic (see page 51).

15 Creative Embroidering

15.1 Overview Embroidering



- | | | | |
|---|--|---|--------------------------|
| 1 | Embroidery Time/Embroidery Design Size | 4 | «i-Dialog» |
| 2 | Scaling Up, Downsizing and Moving the Embroidery Design View | 5 | Embroidery design Layers |
| 3 | Area to be Embroidered | | |

15.2 Selecting and Changing the Embroidery Design



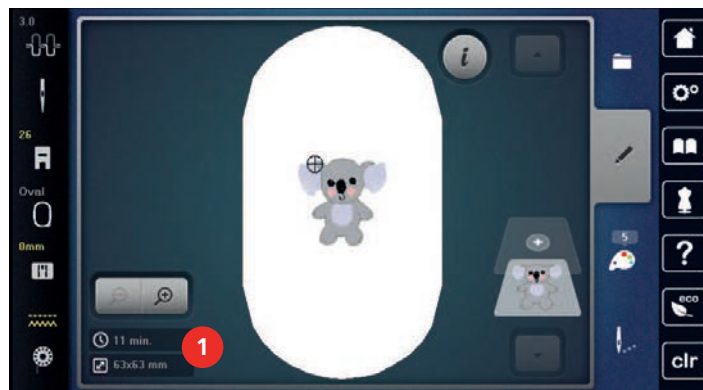
> Tap «Selection».



- > Tap «Loading the Embroidery Design».
- > Select a new embroidery design.

15.3 Checking the Embroidery Time and the Embroidery Design Size

In the selection menu «Edit» the estimated embroidery time in minutes as well as the width and height of the embroidery design is indicated at lower left (1).



15.4 Regulating the Speed

The sewing speed can be adjusted infinitely variable with the slide.

- > Move the slide to the left to reduce the sewing speed.
- > Move the slide to the right to increase the sewing speed.

15.5 Editing the Embroidery Design




Overview Editing embroidery motif



- | | | | |
|---|----------------------------------|----|--|
| 1 | «Move View» | 10 | «Mirror Image Up/Down» |
| 2 | «Moving the Embroidery Design» | 11 | «Duplicating» |
| 3 | «Zoom Out» | 12 | «Deleting an Embroidery Design» |
| 4 | «Zoom In» | 13 | «Check Embroidery Design Size» |
| 5 | «Moving the Embroidery Design» | 14 | «WordArt»
(activated after text entry) |
| 6 | «Rotating the Embroidery Design» | 15 | «Group Embroidery Motifs» |
| 7 | «Change Design Size» | 16 | «Change Embroidery Motif Sequence» |
| 8 | «Pinpoint Placement» | 17 | «Alter Stitch Type/Stitch Density»
(becomes visible by scrolling) |
| 9 | «Mirror Image Left/Right» | | |


Scaling Up the Embroidery Design View

The view of the embroidery design can be scaled up. In addition to that, the view can be adjusted with or without changing the embroidery position.

- > Select the embroidery design.
-  > To edit the view of the embroidery design, tap «Zoom In».
-  > To scale up the view of the embroidery design, tap «Zoom In» 1 up to 4 times.
-  > To get back to the Edit Mode, tap «Zoom Out» 1 up to 4 times.



Downsizing the Embroidery Design

The view of the embroidery design can be downsized. In addition to that, the view can be adjusted with or without changing the embroidery position.

- > Select the embroidery design.
-  > To edit the view of the embroidery design, tap «Zoom In».
-  > To downsize the view of the enlarged embroidery design gradually, tap «Zoom Out» 1 – 4 times.




Moving the Embroidery Design View

The view of the embroidery design can be moved. In addition to that, the view can be adjusted with or without changing the embroidery position.



- > Select the embroidery design.
-  > To activate «Move View», tap «Zoom In».
 - «Move View» is activated (dark gray).
- > Move the view of the embroidery design.
 - The embroidery position is not altered.
-  > To get back to the Edit Mode, tap «Zoom Out».

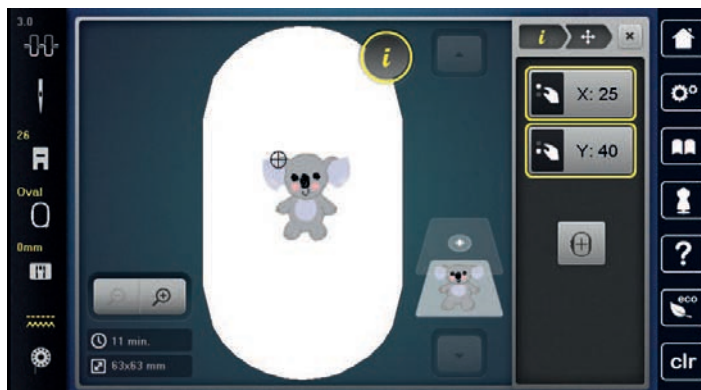
Moving the Embroidery Design in Enlarged View


In addition to that, the view can be adjusted with or without changing the embroidery position. In addition to that, the view can be adjusted with or without changing the embroidery position.

- > Select the embroidery design.
-  > To display the icon «Relocating a Stitch Pattern», tap «Zoom In».
-  > Tap «Moving the Embroidery Design».
 - The icon turns dark gray.
- > Move the view of the embroidery design.
 - The embroidery position is altered.
-  > To get back to the Edit Mode, tap «Zoom Out».


Moving the Embroidery Design



- > Select an embroidery motif.
-  > Tap «i-Dialog».
-  > Tap «Moving the Embroidery Design».
 - > Turn the «Upper Multi-function knob» to move the embroidery motif horizontally in 1/10-mm steps.
 - > Turn the «Lower Multi-function knob» to move the embroidery motif vertically in 1/10 mm steps or tap and hold the embroidery motif to move the embroidery motif as you like.
 - The relocation is indicated in the yellow-outlined icons.



-  > Tap «Centering the Embroidery Design».
 - The embroidery motif is repositioned in the center of the embroidery hoop.

Rotating the Embroidery Design

- > Select the embroidery design.
-  > Tap «i-Dialog».

-  > Tap «Rotating the Embroidery Design».
- > Turn the «Upper Multi-function Knob» or the «Lower Multi-function Knob» to the right to rotate the embroidery design clockwise.
- > Turn the «Upper Multi-function Knob» or the «Lower Multi-function Knob» to the left to rotate the embroidery design counter-clockwise.
-  > To rotate the embroidery design in 90°-steps, tap «Rotate the Embroidery Design +90°».

Altering the Embroidery Design Size Proportionally



Enlargements or reductions of the motif size up to maximum 20 % achieve the best results.

If the motif size is to be altered by more than 20 %, the motif should be adapted in a separate embroidery software and then reloaded onto the machine.



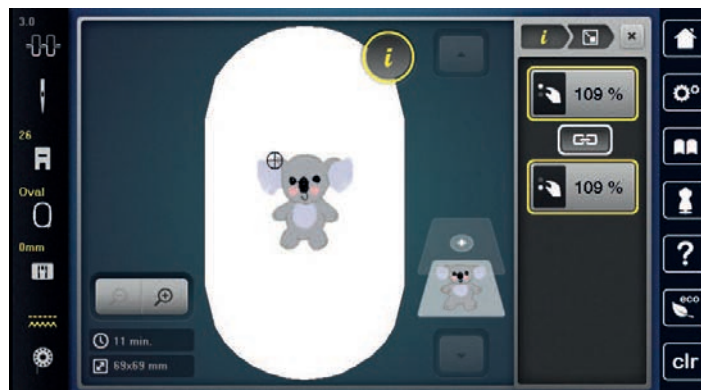
- > Select the embroidery design.
- > Tap «i-Dialog».



- > Tap «Change Design Size».



- > If «Retain Proportions» is not outlined in white, tap «Retain Proportions».
 - «Retain Proportions» is outlined in white.



- > Turn the «Upper/Lower Multi-function Knob» to the right to scale up the embroidery design proportionally.
- > Turn the «Upper/Lower Multi-function Knob» to the left to downsize the embroidery design proportionally.

Altering the Embroidery Design Size Disproportionally



Enlargements or reductions of the motif size up to maximum 20 % achieve the best results.

If the motif size is to be altered by more than 20 %, the motif should be adapted in a separate embroidery software and then reloaded onto the machine.



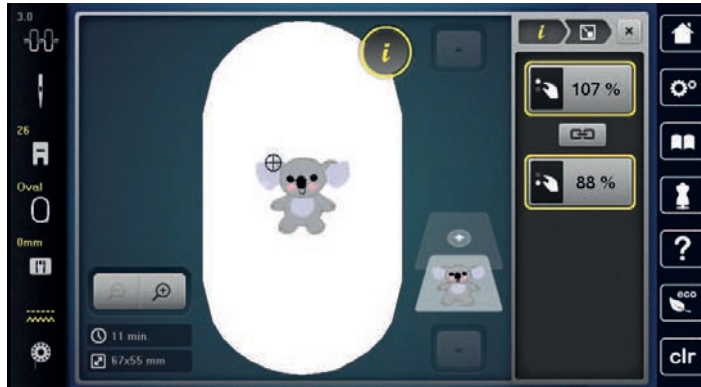
- > Select the embroidery design.
- > Tap «i-Dialog».



- > Tap «Change Design Size».



- > If «Retain Proportions» is outlined in white, tap «Retain Proportions».
- «Retain Proportions» is not outlined in white.



- > To make the embroidery design wider, turn the «Upper Multi-function Knob» clockwise.
- > To make the embroidery design narrower, turn the «Upper Multi-function Knob» anti-clockwise.
- > To make the embroidery design longer, turn the «Lower Multi-function Knob» clockwise.
- > To make the embroidery design shorter, turn the «Lower Multi-function Knob» anti-clockwise.

Mirroring Embroidery Designs

Embroidery designs can be mirror-imaged both vertically and horizontally.



- > Select the embroidery design.
- > Tap «i-Dialog».



- > To mirror the embroidery design horizontally, tap «Mirror Image Left/Right».



- > To mirror the embroidery design vertically, tap «Mirror Image Up/Down».

Changing the Stitch Type

If the satin stitches are too long, they can be changed to step stitches.



- > Select the Embroidery Design.
- > Tap «i-Dialog».



- > Tap «Alter Stitch Type/Stitch Density».



- > Touch the switch in the upper section of the display (1) to change the satin stitch to the step stitch.
- > Set and confirm the stitch length 2.

Altering the Stitch Density

If the satin stitches are embroidered too densely, the stitch density can be adjusted.

- > Select the embroidery design.
- > Tap «i-Dialog».



- > Tap «Alter Stitch Type/Stitch Density».



- > Adjust the stitch density (1).

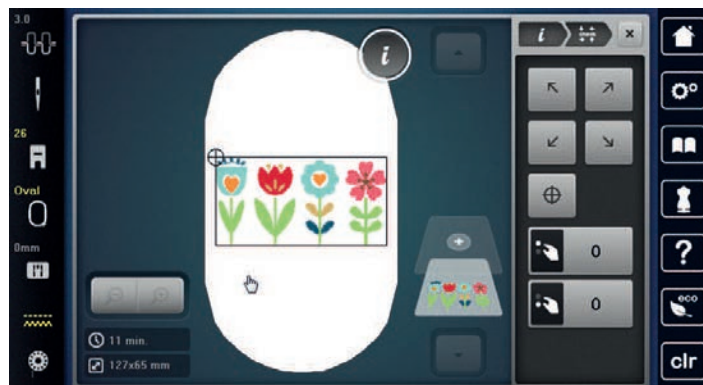
Checking the Size and the Position of the Embroidery Design

It can be checked whether or not the embroidery design matches the designated position/location on the fabric. Points which are beyond the embroidery hoop are not traveled to.

- > Select the embroidery design.
- > Tap «i-Dialog».



- > Tap «Check Embroidery Design Size».
 - The embroidery hoop travels all the way until the needle is at the position as it is indicated in the display.



- > To select the desired corner of the embroidery design, tap the respective arrow.
 - The embroidery hoop travels all the way until the needle is at the position as it is indicated in the display. If the embroidery design hasn't been positioned correctly yet, the position can be altered via the «Upper/Lower Multi-function knobs» and the complete embroidery positions can be checked again.



- > To position the needle in the center of the embroidery design, tap «Center of Embroidery Design».
- > Turn the «Upper Multi-function Knob» to move the embroidery design horizontally.
- > Turn the «Lower Multi-function Knob» to move the embroidery design vertically.

Deleting an Embroidery Design

The active embroidery design is deleted.

- > Select the embroidery design.
- > Tap «i-Dialog».



- > Tap «Deleting».

Changing the sequence within an embroidery motif combination

The sequence of the embroidery motifs in the embroidery motif combination can be changed.

Prerequisite:

- The embroidery motif combination has been created or the motif has been ungrouped.

- > Tap «i-Dialog».



- > Tap «Change Embroidery Motif Sequence».
- > Select the required embroidery motif and move it to the corresponding position.

Grouping embroidery motifs

Embroidery motifs can be added to or removed from a group. The grouped embroidery motifs can be processed in the same way as for one embroidery motif.

The sequence of the embroidery motifs in the group can be changed. (see page 141)

If the grouping of a embroidery motif has been canceled, i.e. the embroidery motif has been broken down into different elements/colors, the colors are no longer combined for new groupings. With alphabets, the length of the connecting stitches must first be set to 1 in the setup. The cancellation of the group then works for all letters.

- > Create an embroidery motif combination.
- > Select the embroidery motif (1) in the embroidery motif combination.



- > Tap «i-Dialog».



- > Tap «Group Embroidery Motifs».



- > Tap «Group».
 - Embroidery motifs above the selected embroidery motif are added to the embroidery motif group.

- > Select the embroidery motif group.



- > Tap «Ungroup».
 - The grouping is canceled.

or

- > Create an embroidery motif combination.
- > Select all embroidery motifs (2).



- > Tap «i-Dialog».



- > Tap «Group».
- All embroidery motifs are added to the embroidery motif group.

- > Select the embroidery motif group.



- > Tap «Ungroup».
- The grouping is canceled.

15.6 Pinpoint Placement

Positioning of grid points

This function allows the exact positioning of the embroidery design on the fabric in an easy way. The positioning points can be placed in the grid.

Prerequisite:

- Any two points of the embroidery design are marked with chalk or a water-soluble pen on the fabric. The place or the location where the embroidery design is to be positioned is clearly visible.
- The hoop in use is selected.

- > Select the embroidery design.



- > Tap «i-Dialog».



- > Tap «Pinpoint Placement».



- > Tap «Grid Point Positioning».
- The embroidery design is given a grid with nine different location/positioning points.



- > To prevent the size of the embroidery design from being changed when positioning the points, tap «Scale the Size of Embroidery Motif».

- > Select the desired positioning point to which the embroidery design is to be adjusted.
- The point changes color.

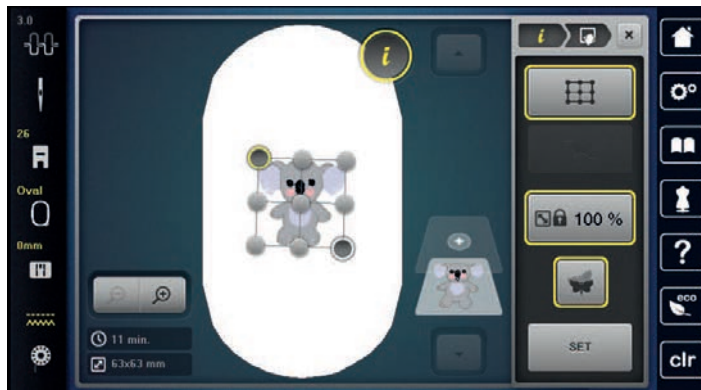
- > Turn the «Upper Multi-function Knob» or the «Lower Multi-function Knob» to the left or to the right to position the needle above the respective mark on the fabric.



- > To confirm the changed position, tap «Set».
- The point changes color and is set.

- > Select the second positioning point of the embroidery design.

- > Turn the «Upper Multi-function Knob» or the «Lower Multi-function Knob» to the left or to the right to position the needle above the respective mark on the fabric.



- > To confirm the changed position, tap «Set».
 - The point changes color and is set. The embroidery design is adjusted accordingly.
- > To reset the changes and revert to the default settings, tap «Reset Pinpoint Placement».



Free point positioning

This function allows the exact positioning of the embroidery design on the fabric in an easy way. The points can be defined as you like within the embroidery design.

Prerequisite:

- Any two points of the embroidery design are marked with chalk or a water-soluble pen on the fabric. The place or the location where the embroidery design is to be positioned is clearly visible.
- The hoop in use is selected.

- > Select the embroidery design.
- > Tap «i-Dialog».



- > Tap «Pinpoint Placement».



- > Tap «Free Point Positioning».



- > To prevent the size of the embroidery design from being changed when positioning the points, tap «Scale the Size of Embroidery Motif».



- > Define a desired point within the embroidery design.
 - The positioning point is displayed.

- > Turn the «Upper Multi-function Knob» or the «Lower Multi-function Knob» to the left or to the right to position the needle above the respective mark on the fabric.

- > To confirm the changed position, tap «Set».
 - The point changes color and is set.



- > Select the second positioning point of the embroidery design.

- > Turn the «Upper Multi-function Knob» or the «Lower Multi-function Knob» to the left or to the right to position the needle above the respective mark on the fabric.



- > To confirm the changed position, tap «Set».
- The point changes color and is set. The embroidery design is adjusted accordingly.
- > To reset the changes and revert to the default settings, tap «Reset Pinpoint Placement».



15.7 Combining Embroidery Designs

Combining Embroidery Designs

In the Combi-mode several embroidery designs can be combined.

- > Select the embroidery design.
- > Tap «Adding an Embroidery Design».

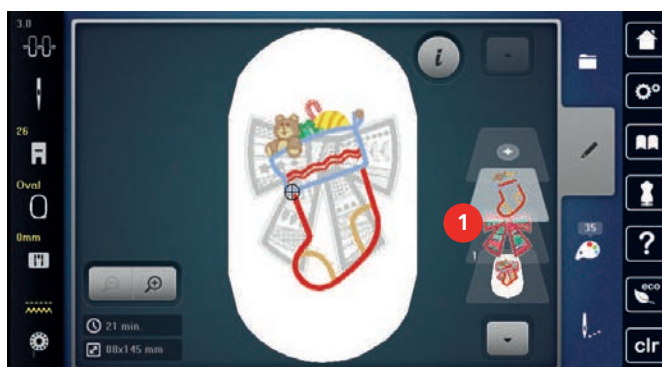


- > Select another embroidery design.

Deleting a Single Embroidery Design

Prerequisite:

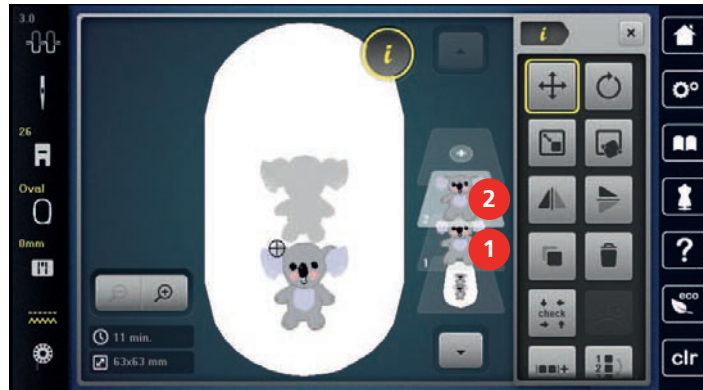
- A combination of embroidery designs has been created.
- > Tap the desired embroidery design in the area of the embroidery design level (1), keep it touched and drag it outwards.
- A new window opens.



- > To delete the selected embroidery design, tap «Confirm».

Duplicating the embroidery motif

- > Select an embroidery motif.
- > Tap «i-Dialog».
- > Tap «Duplicating».
- The embroidery motif (1) is duplicated (2).



Duplicating a combination

When a combination is duplicated, the individual embroidery motifs cannot be selected anymore.

- > Select an embroidery motif.
- > Tap «Adding an Embroidery Design».
- > Select another embroidery motif.
- > Select the combination (1).



- > Tap «i-Dialog».
- > Tap «Duplicating».
- The combination is duplicated (2).

15.8 Creating Lettering

Overview embroidery alphabets

Embroidery motif	Name
ABC	Swiss Block
<i>ABC</i>	Anniversary
Abc	Alphabet Guinevere
ABC	Drifter
ABC	Childs Play
АБВ	Russian Textbook
<i>ABC</i>	Curly
ABC	Rounded Sans

Creating Lettering



- | | | | |
|---|-------------------------|---|---------------------------------------|
| 1 | Entry Field | 5 | «Numbers and Mathematical Characters» |
| 2 | «Deleting» | 6 | «Special Characters» |
| 3 | «Upper Case Characters» | 7 | «Cancel» |
| 4 | «Lower Case Characters» | 8 | «Confirm» |



A lettering is always embroidered in one color. To embroider individual letters or individual words in a different color, the grouping must be canceled.

Lettering can be positioned within the hoop as you like. When the embroidery design is positioned outside the area to be embroidered, the hoop is outlined in red on the display. By means of the hoop selection it is possible to check whether or not the embroidery design can be embroidered in another hoop. If a lettering does not fit into one hoop, individual words can be combined and positioned one below one another, for example.



- > Select «Alphabets».
- > Select an alphabet.
- > Enter and confirm the text.

Editing the Lettering



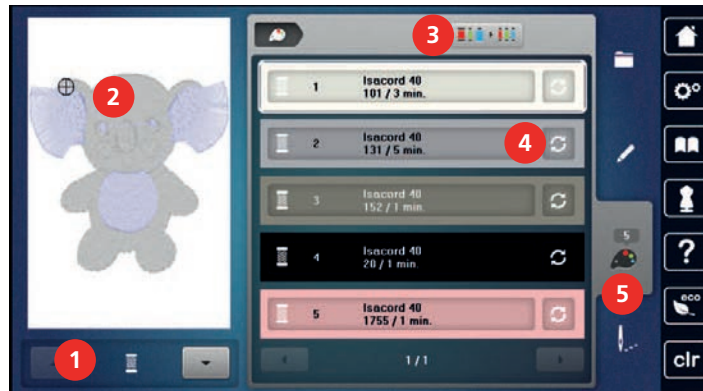
- > A lettering has been created.
- > Tap «i-Dialog».



- > Tap «WordArt».
- > To change the distance between the characters in increments of one millimeter, turn the «Upper Multi-function Knob».
- > Turn the «Lower Multi-function Knob» to the left or right to curve the writing upwards or downwards.

15.9 Changing the Colors of the Embroidery Design

Overview Changing the Color



- | | | | |
|---|----------------------------|---|------------------------|
| 1 | «Color Indication» | 4 | «Altering Color/Brand» |
| 2 | Preview for Selected Color | 5 | «Color Information» |
| 3 | «Assign Thread Brand» | | |

Changing the Colors



- > Select the embroidery design.
- > Tap «Color Information».



- > To change a color, tap «Altering Color/Brand» next to the color to be changed.
- > To display additional colors, swipe up or down on the display.



- > To select the color by entering the color number, tap «Color Selection via Number».
- > Enter the number for the required color.
 - The color icon is displayed on the left.
- > To confirm the color selection, touch the color icon that is displayed on the left.

Changing the Thread Brand



- > Select the embroidery design.
- > Tap «Color Information».



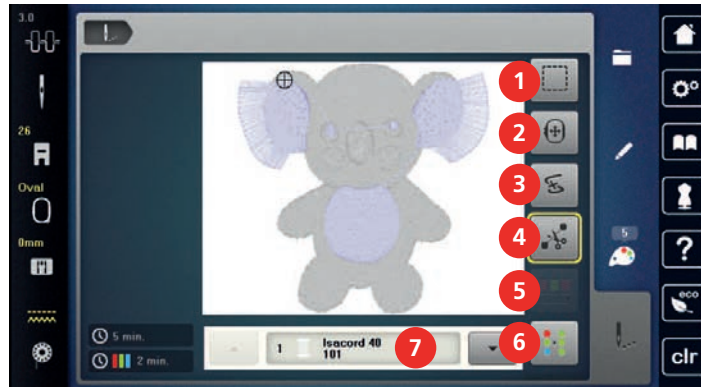
- > Tap «Altering Color/Brand».
- > To display other thread brands, scroll to the left and to the right.



- > Tap «Assign Thread Brand».
- Any thread colors of the selected embroidery design will be matched with the selected thread brand.

15.10 Embroidering the Embroidery Design

Overview Embroidery menu



- | | | | |
|---|-------------------------------|---|--|
| 1 | «Basting» | 5 | «Reduce Color Changes» |
| 2 | «Moving the Hoop» | 6 | «Multi-colored Embroidery Design On/Off» |
| 3 | «Embroidery Sequence Control» | 7 | «Color Indication» |
| 4 | «Cut Connecting Stitches» | | |

Adding Basting Stitches

The basting stitches can be embroidered along the embroidery design. As a result, the fabric and the stabilizer are better fixed together.



- > Select the embroidery design.
- > Tap «Embroidery».



- > To embroider the basting stitches along an embroidery design, tap «Basting».
- > To embroider the basting stitches along the hoop, tap «Basting» again.
- > To deactivate the basting stitches, tap «Basting» again.

Moving the Hoop

If the embroidery design is so big that repeated rehooping is necessary, the embroidered design can be moved again.



- > Select the embroidery design.
- > Tap «Embroidery».



- > Tap «Moving the Hoop».
- > Turn the «Upper Multi-function Knob» to move the embroidery design horizontally.
- > Turn the «Lower Multi-function Knob» to move the embroidery design vertically.



- > To accept the settings, tap «Embroidery» in the Process Navigation.

Embroidery Sequence Control when the Thread Breaks

If the thread breaks, the needle can be repositioned in the embroidery design using the function Embroidery Sequence Control.



- > Select the embroidery design.
- > Tap «Embroidery».



- > Tap «Embroidery Sequence Control».
 - A compact view of the embroidery design appears on the left side of the display. On the right side the embroidery design is shown in enlarged view.
- > Select the desired position in the compact view.
- > Turn the «Upper Multi-function Knob» to move the hoop stitch by stitch.
- > Turn the «Lower Multi-function Knob» to move the hoop in large steps.
 - The number in the yellow-outlined icon indicates the number of stitches within the embroidery sequence.



- > To select the desired stitch by entry, tap the icon «Stitch Position via Number».

Cutting Connecting Stitches

The function is activated as standard and the connection stitches are automatically cut. If the function is deactivated, the connection stitches must be cut by hand.



- > Select the embroidery design.
- > Tap «Embroidery».



- > To switch off the function, tap «Cut Connecting Stitches».
- > To switch on the function, tap «Cut Connecting Stitches» again.

Reducing Color Changes

When the embroidery designs overlap, the color changes **cannot** be reduced.



- > Select the embroidery design.
- > Tap «Embroidery».



- > Tap «Reduce Color Changes».
 - Identical colors of the embroidery design are collected to one color.

Multi-colored Embroidery Design On/Off

Multi-colored embroidery designs can also be embroidered in one color.



- > Select the embroidery design.
- > Tap «Embroidery».



- > Tap «Multi-colored Embroidery Design On/Off».
 - The embroidery design is embroidered in one color.

Color Indication

Every color of the embroidery design can be selected individually. The hoop moves to the first stitch of the current color. The currently active color can be embroidered individually or in another sequence.



- > Select the embroidery design.
- > Tap «Embroidery».
- > Touch the icon Scroll up to select the previous color of the embroidery design.

15.11 Freearm Embroidery

Freearm embroidering is defined as embroidering tubular fabrics or garments which are positioned around the freearm of the embroidery machine while being embroidered. Often used for sleeves, trouser legs or other narrow-tailored garments.



A fabric tube can be comfortably placed around the freearm of the machine if the embroidery hoop is moved to the left into the park position before attaching or removing it. To bring the hoop back into embroidery position afterwards, push the button «Start/Stop».

If possible, use a full bobbin as the embroidery hoop must be removed when the bobbin is changed.

Borders can be closed easily and exactly along the edge of the tube to form a ring.

The mobility of the embroidery arm can be restricted or impeded with very narrow fabric tubes. Therefore make sure that the embroidery hoop can move forwards and backwards sufficiently. An impediment of the embroidery arm caused by a fabric tube which is too tight can result in embroidery motif offset or damage to the fabric.

Check the movability of the freearm

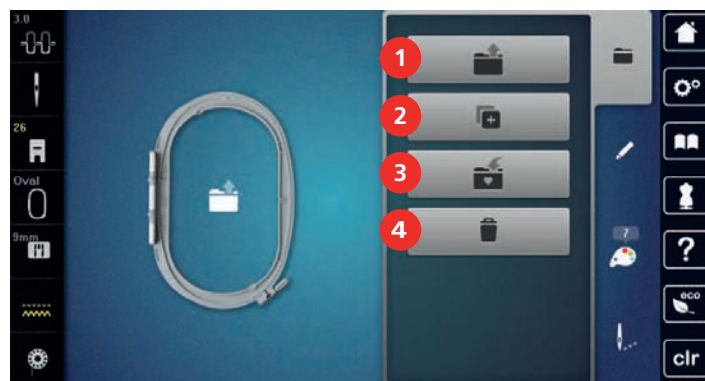
Note: If the fabric tube is narrow, deactivate the Thread Away Mode in the Setup Program.

- > Open the embroidery motif on the machine and edit as desired.
- > Mark the embroidery motif position and the size on the fabric in a suitable way.
- > Select the embroidery hoop as small as possible.
- > Hoop or stick the fabric along with the appropriate stabilizer in the embroidery hoop, depending on the stabilizer.
- > Pull the fabric tube carefully over the freearm of the machine and attach the embroidery hoop at the clutch of the embroidery module.
- > If necessary, reposition the embroidery motif.
- > Tap «Check Embroidery Design Size».
- > After the successful check of the embroidery motif size, start the embroidery process.



15.12 Administering Embroidery Designs

Administering Embroidery Designs



- | | |
|-----------------------------------|-----------------------------------|
| 1 «Loading the Embroidery Design» | 3 «Save Embroidery Design» |
| 2 «Adding an Embroidery Design» | 4 «Deleting an Embroidery Design» |

Saving Embroidery Designs in the Personal Memory

In the file «Save Embroidery Designs» any embroidery designs including individually edited embroidery designs can be saved.

- > Select the embroidery design.
- > Edit the embroidery design.
- > Tap «Selection».



- > Tap «Save Embroidery Design».
- The embroidery design to be saved is outlined in yellow.






- The «Embroidery Machine» is activated.






- > Tap «Confirm».






Saving the Embroidery Design on the BERNINA USB Stick

- > Select the embroidery design.
 - > Edit the embroidery design.
 - > Tap «Selection».
- 
- > Tap «Save Embroidery Design».
 - The embroidery design to be saved is outlined in yellow.
- > Insert the BERNINA USB stick into the USB port of the machine.
 - > Tap «USB Stick».
- 
- > Tap «Confirm».
- 

Overwriting the Embroidery Design in the Personal Memory





- > Select the embroidery design.
 - > Edit the embroidery design.
 - > Tap «Selection».
- 
- > Tap «Save Embroidery Design».
 - The embroidery design to be saved is outlined in yellow.
- 
- The «Embroidery Machine» is activated.
 - > Select the embroidery design which is to be overwritten.
 - > Tap «Confirm».
- 

Overwriting the Embroidery Design on the BERNINA USB Stick

- > Select the embroidery design.
 - > Edit the embroidery design.
 - > Tap «Selection».
- 
- > Tap «Save Embroidery Design».
 - The embroidery design to be saved is outlined in yellow.
- > Insert the BERNINA USB stick into the USB port of the machine.
 - > Tap «USB Stick».
 - > Select the embroidery design which is to be overwritten.
 - > Tap «Confirm».
- 
- 

Importing Stitch Patterns

Stitch patterns or stitch pattern combinations can be imported from sewing mode into embroidery mode and edited like embroidery designs. For example, border designs can be quickly and easily created and saved as embroidery designs in the folder «Personal embroidery designs».

- > Tap «Home».
- 
- > Tap «Sewing Mode».
 - > Select the stitch pattern.
- 
- > Tap «Home».
- 
- > Tap «Embroidery Mode».
 - The stitch pattern is automatically stored in the folder «Personal Embroidery Design».
- 



- > Select «Personal Embroidery Design».
- > Select the stitch pattern.



Loading an Embroidery Design from the Personal Memory



- > Tap «Selection».



- > Tap «Loading the Embroidery Design».



- > Select «Personal Embroidery Design».
- > Select the embroidery design.

Loading an Embroidery Design from the BERNINA USB Stick



- > Tap «Selection».
- > Insert the BERNINA USB stick into the USB port of the machine.



- > Tap «Loading the Embroidery Design».



- > Tap «USB Stick».
- > Select a personal embroidery design.

Deleting an Embroidery Design from the Personal Memory

The embroidery designs which are saved in the personal memory can be deleted individually.



- > Tap «Selection».



- > Tap «Deleting».



- The «Embroidery Machine» is activated.

- > Select the embroidery design which is to be deleted.



- > Tap «Confirm».

Deleting an Embroidery Design from the BERNINA USB Stick



- > Tap «Selection».



- > Tap «Deleting».

- > Insert the BERNINA USB stick into the USB port of the machine.



- > Tap «USB Stick».

- > Select the embroidery design which is to be deleted.



- > Tap «Confirm».

16 Embroidery

16.1 Embroidering via the Button «Start/Stop»

In case of a power cut the embroidery process is interrupted. After the restart the machine goes to the position which was embroidered last.



- > Push the button «Start/Stop» until the embroidery machine starts.
 - All parts of the motif being in the current color are embroidered.
 - The embroidery machine stops automatically at the end.
 - Both threads are cut automatically.
 - The embroidery machine switches to the next color automatically.



- > Change the upper thread.
- > To embroider the new color, push the button «Start/Stop».
 - After finishing the embroidery design, the machine stops automatically and the threads are cut automatically.

16.2 Increasing the Embroidery Speed

To ensure the best embroidery quality, the speed when embroidering is reduced depending on the embroidery position. Choose between the two options to either embroider at optimal or maximum speed. Standard = optimal speed. It has to be considered that the quality of the embroidered embroidery design at maximum speed cannot be ensured.

By switching the machine off and on, the optimal embroidery speed is activated.

Prerequisite:

- Embroidering has started.



- > Tap «Embroidery Speed».
 - The maximum speed is activated.
- > Tap «Embroidery Speed» again.
 - The optimal speed is activated.

16.3 Adjusting the upper thread tension

The default setting of the upper thread tension is set automatically as soon as a stitch pattern or an embroidery motif is selected.

When of using other types of sewing or embroidery threads, the optimal tension may vary. Therefore it may be necessary to adjust the upper thread tension according to the sewing or embroidering project as well as the desired stitch pattern or the embroidery motif individually.

The higher the upper thread tension, the tighter the upper thread which means that the bobbin thread is pulled up to the top of the fabric. When the upper thread tension is low, the upper thread is less tightened which means that the bobbin thread is pulled up less.

Alteration of the upper thread tension affect the currently selected stitch pattern and all embroidery motifs. Permanent alterations of the upper thread tension for the Sewing Mode (see page 48) and for the Embroidering Mode (see page 51) can be made in the Setup Program.



- > Tap «Upper Thread Tension».

- > Adjust the upper thread tension.



- > Tap the yellow-outlined icon on the right side to reset the alterations to the default setting.
- > Tap the yellow-outlined icon on the left side to reset the alteration to default setting in the **Setup Program**.

16.4 Embroidering via the Foot Control

Embroidering with the foot control is recommended if small sequences are to be embroidered, e. g. for stumpwork.

- > To start embroidering, press and keep the foot control pressed.

17 Care and Maintenance

17.1 Firmware

Checking the firmware version

The firmware and hardware versions of the machine and the connected embroidery module are displayed.



> Tap «Setup Program».



> Tap «Machine settings».



> Tap «Information».



> Tap «Machine Data».

Updating firmware



The machine's current firmware and detailed step-by-step instructions for the update process can be downloaded from www.bernina.com. In general, personal data and settings are automatically transferred during a firmware update. For reasons of safety, it is also recommended to save data and settings on a BERNINA USB stick before the firmware update is started. If personal data and settings should get lost during a firmware update, they can be transferred to the machine again afterwards.

Prerequisite:

- Accessories such as the Embroidery module or the BSR Foot which are connected to the machine have been removed.

> Insert the USB stick with the new firmware version into the machine.



> Tap «Setup Program».



> Tap «Machine settings».



> Tap «Maintenance/update».



> Tap «Updating firmware».



> To start the firmware update, tap «Update».

Please note: The update can take several minutes. During the update, do not switch the machine off and do not remove the USB stick.

- The machine restarts. Once the update is complete, a message appears.

Recovering saved data

If personal data and settings after a software update are not available anymore, they can be transferred to the machine again afterwards.

> Insert the BERNINA USB stick providing the saved data and settings into the USB port of the machine.



> Tap «Setup Program».



> Tap «Machine settings».



> Tap «Maintenance/update».



> Tap «Updating firmware».

NOTICE

BERNINA USB Stick (Optional Accessory) has been removed too early

Saved data cannot be transferred and the machine cannot be used.

- > Remove the BERNINA USB stick (optional accessory) only after the saved data has been transferred successfully.



> Tap «Load Data».

- After the data has been transferred, a green tick is temporarily displayed.

17.2 Machine

Cleaning the Display

- > Clean the display when it is switched off with a soft slightly damp microfiber cloth.

Cleaning the Feed Dog

Remaining threads under the stitch plate must occasionally be removed.

- > Raise the needle and presser foot.

CAUTION

Electronically Driven Components

Risk of injury near the needle and the hook.

- > Switch the machine off and disconnect it from the power supply system.

- > Remove the needle and presser foot.
- > Lower feed dog.



- > Remove the stitch plate.

NOTICE

Dust and Thread Residues Inside the Machine

Damage to mechanical and electronic components.

- > Use a brush or a soft cloth.
- > Do not use compressed air spray.

- > Clean the feed dog with the brush.

Cleaning the Hook

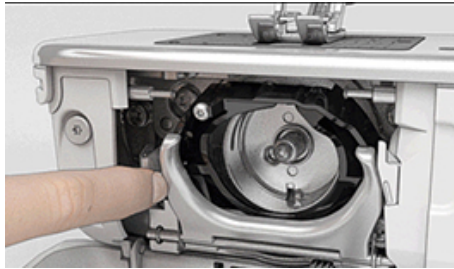
CAUTION

Electronically Driven Components

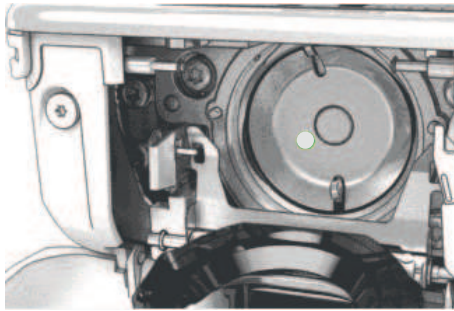
Risk of injury near the needle and the hook.

> Switch the machine off and disconnect it from the power supply system.

- > Open the hook cover.
- > Remove the bobbin case.
- > Push the release bracket to the left.



- > Flap down the fastening bracket along with the black hook race cover.
- > Remove the hook.



NOTICE

Dust and Thread Residues Inside the Machine

Damage to mechanical and electronic components.

- > Use a brush or a soft cloth.
 - > Do not use compressed air spray.
-
- > Clean the hook race area with a brush and a soft cloth. Never use any sharp instruments.
 - > Hold the hook at the pin in the center with two fingers.
 - > Guide the hook with the lower edge diagonally from the top to the bottom behind the hook race cover.
 - > Position the hook so that the two lugs on the hook driver fit into the corresponding openings on the hook, and the colored marking on the hook driver is visible in the hole of the hook.
 - > Insert the hook.
 - The hook is magnetic and therefore fastened to the correct position.
 - > Close the hook race cover and the fastening bracket until the release bracket engages.
 - > As a check, turn the handwheel.
 - > Insert the bobbin case.

Lubricating the Hook

By oiling the hook, the occurrence of unwanted noises in the hook area can be avoided. BERNINA recommends oiling the hook at the following intervals:

- Before using the machine for the first time
- After a longer downtime of the machine
- For intensive use: Daily before sewing
- When the message " Lubricate the Machine " is displayed
- In case of unwanted noises in the hook area

CAUTION

Electronically Driven Components

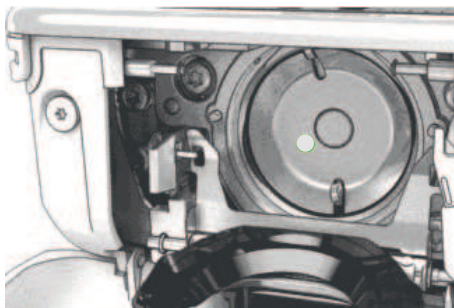
Risk of injury near the needle and the hook.

- > Switch the machine off and disconnect it from the power supply system.

- > Remove the bobbin case.
- > Push the release bracket to the left.



- > Flap down the fastening bracket along with the black hook race cover.
- > Remove the hook.



- > Clean the hook race area with a brush and a soft cloth. Never use any sharp instruments.
- > Add one drop of BERNINA oil down into the hook race.



- > Add one drop of oil into each of the two oil depots so that the felts are damp, and make sure that the red-marked surface of the hook sleeve remains free of oil.

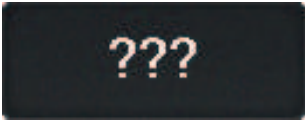


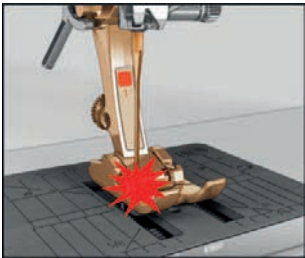

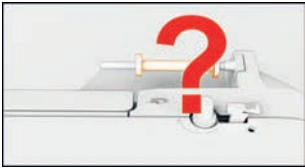



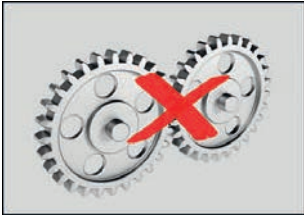
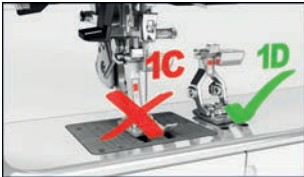
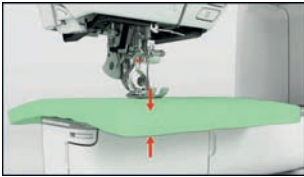
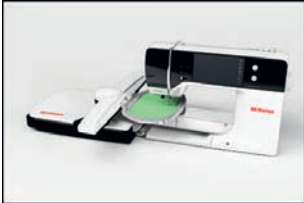
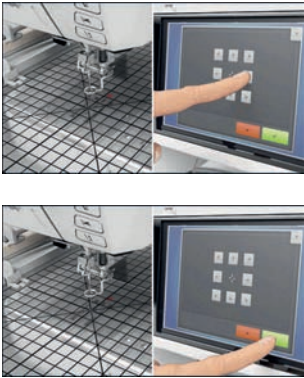

- > Hold the hook at the pin in the center with two fingers.
- > Guide the hook with the lower edge diagonally from the top to the bottom behind the hook race cover.
- > Position the hook so that the two lugs on the hook driver fit into the corresponding openings on the hook, and the colored marking on the hook driver is visible in the hole of the hook.
- > Insert the hook.
 - The hook is magnetic and therefore fastened to the correct position.

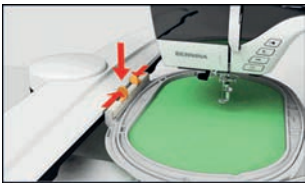
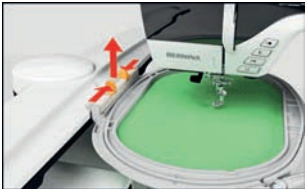
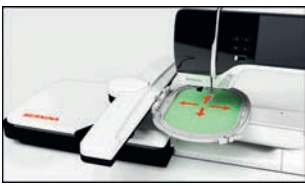





18 Errors and Faults


18.1 Error messages

Message on the Display	Cause	Solution
	Stitch number unknown.	> Check the entry and enter the new number.
	Selection of stitch patterns not possible in Combi-mode.	> Combine other stitch patterns.
	The feed dog is not lowered.	> To lower the feed dog, push the button «Feed Dog Up/Down».
	The selected needle and stitch plate cannot be used in combination.	> Replace the needle. > Replace the stitch plate.
	The needle is not at its top end.	> Adjust the needle position via the handwheel.
	The upper thread is used up.	> Rethread.
	The upper thread has broken.	> Rethread.
	The bobbin thread is used up.	> Rethread.
	The bobbin thread has broken.	> Clean the hook. > Rethread.

Message on the Display	Cause	Solution
	The main motor is not running.	<ul style="list-style-type: none"> > Turn the handwheel clockwise until the needle is at its top position. > Remove the sewing project. Do not pull on the fabric or the thread. > Remove the stitch plate. > Remove the thread remnants. > Clean the hook. > Remove the hook and make sure that there are no pieces of broken needle points on the magnetic back of the hook. > Insert the hook correctly. > Deactivate the thread catcher in the Setup Program.
	Incorrect presser foot for the BERNINA Dual Feed.	<ul style="list-style-type: none"> > Fit a presser foot with the designation «D».
	The fabric under the presser foot is too thick.	<ul style="list-style-type: none"> > Reduce the fabric thickness.
	The contact between the machine and the embroidery module is interrupted as a result of vibrations.	<ul style="list-style-type: none"> > Make sure that the embroidery module and the machine are standing on a stable, even surface. > Connect the embroidery module to the machine.
	The needle position doesn't correspond with the center of the hoop.	<ul style="list-style-type: none"> > Calibrate the hoop.
	The embroidery module is not attached.	<ul style="list-style-type: none"> > Connect the embroidery module to the machine. > Contact the specialized BERNINA dealer to have the machine checked.

Message on the Display	Cause	Solution
	The hoop is not attached.	> Attach the hoop.
	The hoop is attached.	> Remove the embroidery hoop.
	The movement of the hoop follows.	> Tap «Confirm».
	The embroidery design is partly outside the hoop.	> Reposition the embroidery design and start embroidering it again.
	The embroidery design is too large.	> Reduce the size of the embroidery design. > Attach a larger hoop.
Not enough free capacity on the BERNINA USB stick (optional accessory).	There is not enough free capacity on the BERNINA USB stick (optional accessory).	> Make sure that the BERNINA USB stick (optional accessory) is used. > Delete data from the BERNINA USB stick (optional accessory).
No personal data on the BERNINA USB stick (optional accessory).	No personal data for recovery available on the BERNINA USB stick (optional accessory).	> Make sure that the data and settings have been saved on the BERNINA USB stick (optional accessory).
The recovery of personal data has failed.	The firmware update has been successful but the personal data could not be recovered.	> Make sure that the data and settings have been saved on the BERNINA USB stick. > Transfer saved data to the machine.


Message on the Display	Cause	Solution
No BERNINA USB stick is inserted. Make sure that the same BERNINA USB stick remains connected during the entire automatic update process.	The BERNINA USB stick (optional accessory) is not inserted.	<ul style="list-style-type: none"> > Use a BERNINA USB stick (optional accessory) which provides enough free capacity.
The firmware update has failed.	The latest firmware version cannot be found on the USB stick.	<ul style="list-style-type: none"> > Make sure that the compressed zip file has been unzipped for the firmware update. > Check whether the data for the software update is saved directly on the data medium and not in a file on the USB stick. > Updating Firmware.
	The machine must be cleaned/lubricated.	<ul style="list-style-type: none"> > Clean the machine. > Lubricate the machine. <p>Important information on lubricating:</p> <ul style="list-style-type: none"> > Too much oil may stain the fabric and the thread. > After lubricating, sew/embroider a test piece first.
The automatic thread cutter (at the thread catcher) needs cleaning.	The automatic thread cutter needs cleaning. The message appears every time when the machine is started as soon as 1000 cutting cycles have been carried out.	<ul style="list-style-type: none"> > Tap «Confirm». <ul style="list-style-type: none"> – The machine calls up the function «Clean the Thread Catcher». > Clean the thread catcher according to the instructions on the display. <ul style="list-style-type: none"> – The counter for the cutting cycles is reset.
It is time for the regular maintenance. Please contact your authorized BERNINA dealer to make an appointment.	<p>The machine needs maintenance. The message appears after the programmed service interval has expired.</p> <p>Important Information: Having your machine cleaned and serviced properly at the appropriate times ensures its proper functioning and a long service life. In case of non-compliance, the service life may be negatively affected and the warranty service may possibly become limited. The cost allocation for maintenance work is regulated nationally. Consult your authorized BERNINA dealer or your service center for more details.</p>	<ul style="list-style-type: none"> > Contact an authorized BERNINA dealer. > Delete the message temporarily by touching the icon «ESC». <p>After the third deletion, the message is not displayed until the next service interval is reached.</p>

Message on the Display	Cause	Solution
	<p>The calibration of the Buttonhole Foot with Slide #3A has failed.</p>	<ul style="list-style-type: none"> > Check the presser foot for ease of movement. If necessary, remove lint, dust and fabric remnants. > Clean the reflector with a soft, slightly damp microfiber cloth. > Check the position of the reflector. If necessary, correct the position of the reflector or replace the presser foot. > Check the plastic on the underside of the presser foot for signs of wear. If necessary, replace the presser foot. > Clean the feed dog. > If the error still occurs, contact your authorized BERNINA dealer.
#1000	The needle threader is jammed.	<ul style="list-style-type: none"> > Switch off the machine. Press the needle threader down and release it again. Switch the machine on. > If the error still occurs, contact your authorized BERNINA dealer.
#1001	The button «Thread Cutter» is stuck or defective.	<ul style="list-style-type: none"> > Make sure that the button can be operated without restriction. > If the error still occurs, contact your authorized BERNINA dealer.
#1002	The button «Needle position Up/Down» is stuck or defective.	<ul style="list-style-type: none"> > Make sure that the button can be operated without restriction. > If the error still occurs, contact your authorized BERNINA dealer.
#1003	The button «Start/Stop» is stuck or defective.	<ul style="list-style-type: none"> > Make sure that the button can be operated without restriction. > If the error still occurs, contact your authorized BERNINA dealer.
#1004 #1005 #1010	The exact cause of the malfunction cannot be determined.	<ul style="list-style-type: none"> > Restart the machine. > If the error still occurs, contact your authorized BERNINA dealer.

18.2 Troubleshooting

Fault	Cause	Solution
Uneven stitch formation	Upper thread too tight or too loose.	<ul style="list-style-type: none"> > Adjust the upper thread tension. > Check the thread feed from the thread spool.
	Needle blunt or bent.	> Replace the needle, make sure that a new BERNINA quality needle is used.
	Poor quality needle.	> Use a new BERNINA quality needle.
	Poor quality thread.	> Use quality thread.
	Incorrect needle/thread combination.	> Match the needle with the thread size.
	Incorrectly threaded.	> Rethread.
	Fabric was pulled.	> Feed the fabric evenly.
Uneven stitch formation	Incorrect bobbin case is used.	> Use the supplied bobbin case marked with the triangle.
Skipped stitches	Incorrect needle.	> Use the needle system 130/705H.
	Needle blunt or bent.	> Replace the needle.
	Poor quality needle.	> Use a new BERNINA quality needle.
	The needle is incorrectly inserted.	> Insert the needle with the flat side to the back as far up as it will go into the needle holder and tighten the screw.
	Incorrect needle point.	> Match the needle point to the texture of the material.
Faulty stitching	Thread remnants between the thread tension discs.	> Fold a piece of thin material and slide the folded edge (not the raw edges) between the thread tension discs.
	Incorrectly threaded.	> Rethread.
	Thread remnants below the bobbin case spring.	> Remove the thread remnants under the spring.



Fault	Cause	Solution
Upper thread breaks	Incorrect needle/thread combination.	> Match the needle with the thread size.
	Upper thread is too tight.	> Reduce the upper thread tension.
	Incorrectly threaded.	> Rethread.
	Poor quality thread.	> Use quality thread.
	The stitch plate or the hook tip is damaged.	> Contact the nearest specialized BERNINA dealer to have the damages repaired. > Replace the stitch plate.
	The thread is caught in the area of the thread take-up lever.	> Remove the screw (1) on the headframe with the angular Torx Screwdriver. > Pull the headframe at the bottom slightly forward. > Flip the headframe upwards a bit and remove it. > Remove the thread remnants. > Attach the headframe and tighten the screw.
		
Lower thread breaks	The bobbin case is damaged.	> Replace the bobbin case.
	The stitch hole in the stitch plate is damaged.	> Contact the nearest specialized BERNINA dealer to have the damages repaired. > Replace the stitch plate.
	Needle blunt or bent.	> Replace the needle.
Needle breaks	The needle is incorrectly inserted.	> Insert the needle with the flat side to the back as far up as it will go into the needle holder and tighten the screw.
	Fabric was pulled.	> Feed the fabric evenly.
	Thick fabric has been pushed.	> Use a suitable presser foot, e. g. Jeans Foot #8, for thick fabric. > Use the height compensating tool when sewing over a thick seam.
	Knotted thread.	> Use quality thread.
Display is inactive	Incorrect calibrating data.	> Recalibrate the display. (see page 56) > If calibration cannot be selected in the Setup Program, switch the machine on again while simultaneously pushing and holding the buttons «Needle Position Right/Left».
	The eco Mode is active.	> Tap «eco Mode».

Fault	Cause	Solution
Stitch width not adjustable	The selected needle and stitch plate cannot be used in combination.	<ul style="list-style-type: none"> > Replace the needle. > Replace the stitch plate.
	The «Presser Foot Indicator/Presser Foot Selection» prevents the adjustment of the stitch width.	<ul style="list-style-type: none"> > Select the attached presser foot.
Speed too low	Unfavorable room temperature.	<ul style="list-style-type: none"> > Place the machine in a warm room one hour before use.
	Settings in the Setup Program.	<ul style="list-style-type: none"> > Adjust the sewing speed in the Setup Program. > Adjust the slide.
The machine doesn't start	Unfavorable room temperature.	<ul style="list-style-type: none"> > Place the machine in a warm room one hour before use. > Connect the machine and switch it on.
	The machine is damaged.	<ul style="list-style-type: none"> > Contact an authorized BERNINA dealer.
The light of the button «Start-/Stop» doesn't light up	Light is defect.	<ul style="list-style-type: none"> > Contact an authorized BERNINA dealer.
Neither the sewing light nor the light on the freearm lights up	Settings in the Setup Program.	<ul style="list-style-type: none"> > Activate it in the Setup Program.
	The sewing light is defect.	<ul style="list-style-type: none"> > Contact an authorized BERNINA dealer.
Upper thread indicator fails to respond	Settings in the Setup Program.	<ul style="list-style-type: none"> > Activate it in the Setup Program.
	The upper thread indicator is defect.	<ul style="list-style-type: none"> > Contact an authorized BERNINA dealer.
Bobbin thread indicator doesn't react	Settings in the Setup Program.	<ul style="list-style-type: none"> > Activate it in the Setup Program.
	The bobbin thread indicator is defect.	<ul style="list-style-type: none"> > Contact an authorized BERNINA dealer.
Error during firmware update	USB stick is not recognized.	<ul style="list-style-type: none"> > Use the BERNINA USB stick.
	The update process is blocked and the hourglass on the display is inactive.	<ul style="list-style-type: none"> > Remove the USB stick. > Switch off the machine. > Switch the machine on. > Follow the instruction on the display.
	Firmware update files are not found.	<ul style="list-style-type: none"> > Unzip the update data. > Store data for the firmware update directly on the data medium and not in a folder on the USB stick.
BSR Presser Foot #42 not detected	Lens is dirty.	<ul style="list-style-type: none"> > Clean the lens with a soft, slightly damp cloth.
	BSR cable not inserted correctly.	<ul style="list-style-type: none"> > Insert the BSR connector vertically until it can be felt to click into place.
Beads and/or bartacks are repeatedly not sewn properly	The Buttonhole Foot with Slide #3A is not calibrated with the machine.	<ul style="list-style-type: none"> > Calibrate Buttonhole Foot with Slide #3A. (see page 58)

19 Storage and Disposal

19.1 Storing the Machine

It is recommended to store the machine in the original packaging. If the machine is stored in a cold room, place it in a warm room one hour before use.

- > Switch the machine off and disconnect it from the power supply.
- > Don't store the machine outdoors.
- > Protect the machine against climatic influences.

19.2 Dispose of the Machine

- > Clean the machine.
- > Sort the components by their materials and dispose of them according to the local laws and regulations.



20 Technical data

Designation	Value	Unit
Maximum fabric thickness	12.5 (0.49)	mm (in)
Sewing light	30	LED
Maximum speed	1000	Stitches per minute
Measurements without the spool pin (W × H × D)	522 × 358 × 214 (20.55 × 14.09 × 8.43)	mm (in)
Weight	14 (30.86)	kg (lb)
Energy consumption	140	W
Input voltage	100 – 240	V
Protection class (Electrical engineering)	II	

21 Overview Stitch Patterns

21.1 Overview Stitch Patterns

Practical Stitches

1	2	3	4	5	6	7	8	9	10	11	12	13	14
15	16	17	18	19	20	21	22	23	24	25	26	27	29
31	32	33	34	35	36	37	38	39	40				

Buttonholes

51	52	53	54	55	56	57	58	59	60	61	62	63	64
65	67	68	69	70									

Decorative Stitches

Nature Stitches

101	102	103	104	105	106	107	108	109	110	111	112	113	114
115	116	117	118	119	122	123	124	125	126	127	128	129	130
131	132	134	136	137	138	139	140	141	142	143	144	145	146
147	148	150	152	153	154	155	156	159	160	161	165	166	167
168	169	170	171	172	173	174	175	176	177	178	179	180	181
182	183	184	185										

Cross Stitches

301	302	303	304	305	306	307	308	309	311	313	314	319	320
321	322	323	324	325	326	327	328	329	330	331	332	333	334
335	336	337	338	339	371	372	373	374	375	376	377	378	

Satin Stitches

401	402	405	406	407	408	409	410	412	413	414	415	416	417
418	419	421	422	423	424	425	426	427	428	429	430	431	433
434	436	437	440	442	443	444	445	447	448	449	450	451	452
453	454	455	456	457	458	461	464	465	466	468	469	471	472
473													

Geometric Stitches

601	602	603	604	605	606	607	608	609	610	611	612	613	614
615	616	618	619	620	621	622	623	624	625	626	627	628	629
630	631	632	633	634	635	636	637	639	640	641	642	643	644
645	646	647	648	649	650	651	652	653	654	655	656	657	658

Overview Stitch Patterns

660	661	662	663	664	665	666	674	675	676	677	678	679	680
682	683	684	685	686	691	694							

White Embroidery

701	702	703	704	705	706	707	708	709	710	711	712	713	714
715	716	717	721	722	723	724	725	726	727	729	730	731	732
733	734	735	736	737	738	739	740	741	742	743	744	745	746
747	748	749	750	751	752	756	762	764	765	767	768	769	770
771	772	773	774	775	776	777	778	779	780	781	782	783	

Children Stitches

901	902	903	904	905	906	907	908	909	910	911	912	913	914
915	916	917	918	919	920	921	922	924	926	928	929	935	937
938	939	940	944	945	946	948	949	950	952	954	955	957	958
959	960	961	962										

International

1701	1702	1703	1704	1705	1706	1707	1708	1709	1710	1711	1715	1716	1717
------	------	------	------	------	------	------	------	------	------	------	------	------	------

1718	1719	1720	1721	1722	1723	1729	1730	1731	1732	1733	1735	1736

Seasons

2001	2002	2003	2004	2005	2006	2007	2008	2009	2015	2016	2017	2018	2019
2020	2021	2022	2023										

Sport and Hobbies

2201	2202	2203	2204	2205	2206	2207	2209	2210	2211	2212	2213	2215	2216
2217	2218	2219											

Quilt Stitches

1301	1302	1303	1304	1305	1306	1307	1308	1309	1310	1311	1312	1313	1314
				 6 / inch 2.4 / cm	 8 / inch 3.2 / cm	 10 / inch 4 / cm	irregular look						
1315	1316	1317	1318	1319	1320	1321	1322	1323	1324	1325	1326	1327	1329
1330	1331	1332	1333	1334	1335	1336	1337	1338	1339	1340	1341	1342	1343
1344	1345	1346	1363	1364	1365	1366	1367	1368	1369	1370	1371	1373	1374
1375	1376	1377	1378	1379	1380	1381	1382	1384	1385	1386	1387	1388	1389
1390	1391	1393	1394										









21.2 Overview Embroidery Desings

Editing the Embroidery Design

Let your creativity run free. A vast selection of embroidery designs is at your disposal.

If you see one of the following pictograms below a number of the embroidery design, you can find additional information at

<https://www.bernina.com/specialeffects>.

	Detached Point		PunchWork
	Basic CutWork		Couching
	Fringe Embroidery		Projects in the Hoop
	Appliqué		Puffy Fonts
	CutWork		Quilting
	PaintWork		Trapunto
	CrystalWork		

Quilt motifs

 Bd380  103 x 103 mm 4 x 4.1 inch  2.976 1.  Isacord 40 5822	 Bd378  64 x 64 mm 2.5 x 2.5 inch  820 1.  Isacord 40 5822
 Bd379  96 x 96 mm 3.8 x 3.8 inch  1.639 1.  Isacord 40 5822	 Bd381  62 x 64 mm 2.4 x 2.5 inch  866 1.  Isacord 40 5822
 Bd382  80 x 69 mm 3.2 x 2.7 inch  756 1.  Isacord 40 5822	 Bd383  80 x 80 mm 3.1 x 3.1 inch  1.690 1.  Isacord 40 5822

Bd384  46 x 46 mm
1.8 x 1.8 inch  430



1.  Isacord 40 5822




Bd385  46 x 92 mm
1.8 x 3.6 inch  852



1.  Isacord 40 5822



Bd386  93 x 91 mm
3.6 x 3.6 inch  1.572

1.  Isacord 40 5822



Bd387  67 x 67 mm
2.6 x 2.6 inch  741

1.  Isacord 40 5822



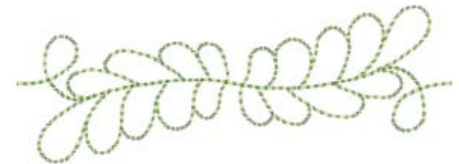
Bd388  101 x 33 mm
4 x 1.3 inch  661

1.  Isacord 40 5822



Bd389  101 x 36 mm
4 x 1.4 inch  837

1.  Isacord 40 5822



Bd390  101 x 32 mm
4 x 1.2 inch  925



1.  Isacord 40 5822



Bd391  43 x 55 mm
1.7 x 2.2 inch  620



1.  Isacord 40 5822



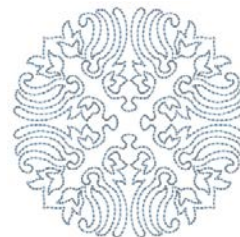
Bd392  52 x 68 mm
2.1 x 2.7 inch  632



1.  Isacord 40 5822




Bd395_48  96 x 96 mm
3.8 x 3.8 inch  5.672



1.  Isacord 40 3641



Bd396_48  97 x 97 mm
3.8 x 3.8 inch  3.728






















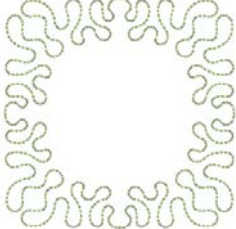























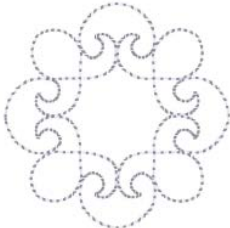


1.  Isacord 40 3641



Bd403_48  97 x 97 mm
3.8 x 3.8 inch  5.309

1.  Isacord 40 1430

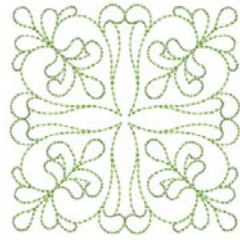


Bd407_48  51 x 41 mm 2 x 1.6 inch  974	Bd408_48  80 x 80 mm 3.1 x 3.1 inch  2.468
1.  Isacord 40 1335 	1.  Isacord 40 1335 
Bd409_48  55 x 74 mm 2.2 x 2.9 inch  1.838	Bd410_48  75 x 75 mm 2.9 x 2.9 inch  2.555
1.  Isacord 40 1335 	1.  Isacord 40 1335 
Bd414_48  97 x 97 mm 3.8 x 3.8 inch  2.738	Bd415_48  97 x 97 mm 3.8 x 3.8 inch  3.212
1.  Isacord 40 5822 	1.  Isacord 40 5822 
Bd416_48  97 x 97 mm 3.8 x 3.8 inch  2.168	Bd364  89 x 89 mm 3.5 x 3.5 inch  1.373
1.  Isacord 40 5822 	1.  Isacord 40 3150 
Bd370  46 x 93 mm 1.8 x 3.7 inch  1.028	Bd373  103 x 34 mm 4 x 1.3 inch  770
1.  Isacord 40 3150 	1.  Isacord 40 3150 
Bd367  65 x 65 mm 2.6 x 2.6 inch  1.124	Bd566_48  110 x 59 mm 4.3 x 2.3 inch  2.260
1.  Isacord 40 3150 	1.  Isacord 40 5531 



Bd565_48 99 x 99 mm 3.9 x 3.9 inch 4.424

1. Isacord 40 5531



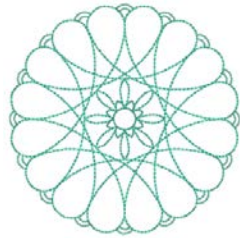
Bd558_48 104 x 104 mm 4.1 x 4.1 inch 4.472

1. Isacord 40 4620



12499-06 102 x 102 mm 4 x 4 inch 3.838

1. Isacord 40 5115



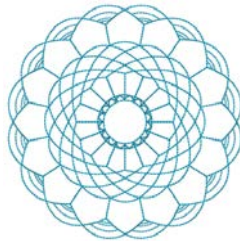
12499-04 123 x 123 mm 4.9 x 4.8 inch 7.229

1. Isacord 40 5610



12499-05 123 x 123 mm 4.9 x 4.9 inch 6.317

1. Isacord 40 4103



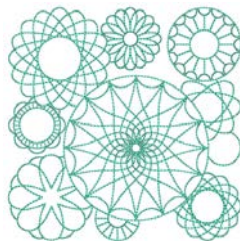
12499-24 133 x 215 mm 5.2 x 8.4 inch 11.445

1. Isacord 40 4103



12499-23 123 x 123 mm 4.9 x 4.9 inch 11.194

1. Isacord 40 5115



12607-20 122 x 122 mm 4.8 x 4.8 inch 1.055

1. Isacord 40 0020



12607-21 61 x 122 mm 2.4 x 4.8 inch 657

1. Isacord 40 0020



12416-04 89 x 89 mm 3.5 x 3.5 inch 3.482

1. Isacord 40 0721



12416-03 124 x 124 mm 4.9 x 4.9 inch 5.909

1. Isacord 40 0721










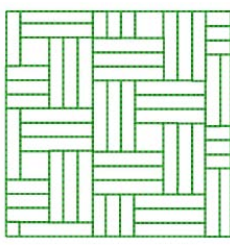







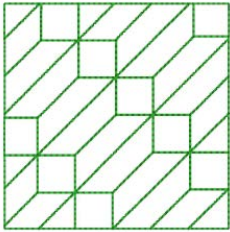

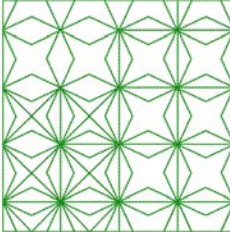







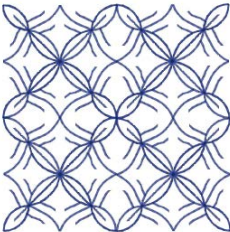

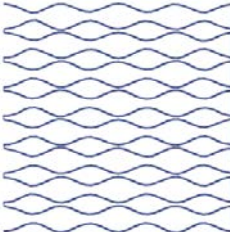

















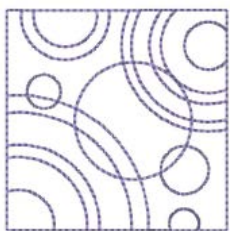














12416-26 44 x 174 mm 1.7 x 6.9 inch 2.816

1. Isacord 40 3830



Overview Stitch Patterns

 12416-48	 171 x 178 mm 6.7 x 7 inch	 9.050	 Nb346_48	 76 x 76 mm 3 x 3 inch	 3.366
<p>1.  Isacord 40 5610</p> 			<p>1.  Isacord 40 5513</p> 		
 Nb347_48	 76 x 76 mm 3 x 3 inch	 2.337	 Nb334_48	 127 x 127 mm 5 x 5 inch	 6.838
<p>1.  Isacord 40 5513</p> 			<p>1.  Isacord 40 5513</p> 		
 Nz498	 89 x 89 mm 3.5 x 3.5 inch	 2.642	 Nz503	 99 x 99 mm 3.9 x 3.9 inch	 2.103
<p>1.  Isacord 40 3353</p> 			<p>1.  Isacord 40 3353</p> 		
 82013-29	 121 x 121 mm 4.8 x 4.8 inch	 5.644	 82013-30	 83 x 166 mm 3.3 x 6.5 inch	 2.774
<p>1.  Isacord 40 2920</p> 			<p>1.  Isacord 40 2920</p> 		
 82013-31	 57 x 58 mm 2.3 x 2.3 inch	 1.884	 82013-32	 122 x 105 mm 4.8 x 4.1 inch	 4.506
<p>1.  Isacord 40 2920</p> 			<p>1.  Isacord 40 2920</p> 		
 12416-24	 89 x 73 mm 3.5 x 2.9 inch	 2.330	 12607-16	 123 x 122 mm 4.8 x 4.8 inch	 1.222
<p>1.  Isacord 40 3830</p> 			<p>1.  Isacord 40 0020</p> 		



12616-16 123 x 123 mm 4.8 x 4.8 inch 1.198

1. Isacord 40 5422



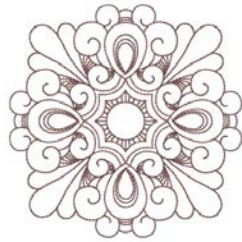
12380-22 110 x 61 mm 4.4 x 2.4 inch 2.487

1. Isacord 40 1543



12380-43 123 x 123 mm 4.9 x 4.9 inch 8.248

1. Isacord 40 1543



12380-30 89 x 96 mm 3.5 x 3.8 inch 4.442

1. Isacord 40 1543



12380-04 83 x 90 mm 3.3 x 3.5 inch 2.189

1. Isacord 40 1543



12380-08 89 x 89 mm 3.5 x 3.5 inch 2.725

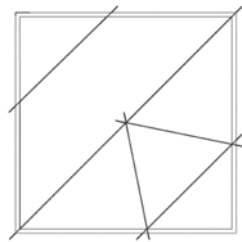
1. Isacord 40 1543



Quilting in the hoop

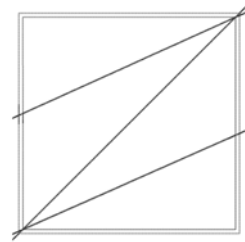
12736-01 140 x 140 mm 5.5 x 5.5 inch 1.657

1. Isacord 40 0020
2. Isacord 40 0020
3. Isacord 40 0020
4. Isacord 40 0020
5. Isacord 40 0020
6. Isacord 40 0020
7. Isacord 40 0020
8. Isacord 40 0020
9. Isacord 40 0020
10. Isacord 40 0020
11. Isacord 40 0020
12. Isacord 40 0020



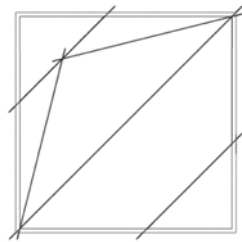
12736-02 140 x 139 mm 5.5 x 5.5 inch 1.473

1. Isacord 40 0020
2. Isacord 40 0020
3. Isacord 40 0020
4. Isacord 40 0020
5. Isacord 40 0020
6. Isacord 40 0020
7. Isacord 40 0020
8. Isacord 40 0020



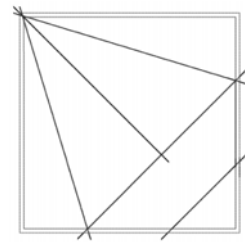
12736-03 140 x 140 mm 5.5 x 5.5 inch 1.776

1. Isacord 40 0020
2. Isacord 40 0020
3. Isacord 40 0020
4. Isacord 40 0020
5. Isacord 40 0020
6. Isacord 40 0020
7. Isacord 40 0020
8. Isacord 40 0020
9. Isacord 40 0020
10. Isacord 40 0020
11. Isacord 40 0020
12. Isacord 40 0020



12736-04 140 x 140 mm 5.5 x 5.5 inch 1.846

1. Isacord 40 0020
2. Isacord 40 0020
3. Isacord 40 0020
4. Isacord 40 0020
5. Isacord 40 0020
6. Isacord 40 0020
7. Isacord 40 0020
8. Isacord 40 0020
9. Isacord 40 0020
10. Isacord 40 0020
11. Isacord 40 0020
12. Isacord 40 0020



12736-05 140 x 136 mm
5.5 x 5.3 inch 1.329

1. ■ Isacord 40 0020
2. ■ Isacord 40 0020
3. ■ Isacord 40 0020
4. ■ Isacord 40 0020
5. ■ Isacord 40 0020
6. ■ Isacord 40 0020
7. ■ Isacord 40 0020
8. ■ Isacord 40 0020

12736-06 140 x 140 mm
5.5 x 5.5 inch 1.563

1. ■ Isacord 40 0020
2. ■ Isacord 40 0020
3. ■ Isacord 40 0020
4. ■ Isacord 40 0020
5. ■ Isacord 40 0020
6. ■ Isacord 40 0020
7. ■ Isacord 40 0020
8. ■ Isacord 40 0020
9. ■ Isacord 40 0020
10. ■ Isacord 40 0020

12736-07 140 x 140 mm
5.5 x 5.5 inch 1.877

1. ■ Isacord 40 0020
2. ■ Isacord 40 0020
3. ■ Isacord 40 0020
4. ■ Isacord 40 0020
5. ■ Isacord 40 0020
6. ■ Isacord 40 0020
7. ■ Isacord 40 0020
8. ■ Isacord 40 0020
9. ■ Isacord 40 0020
11. ■ Isacord 40 0020
12. ■ Isacord 40 0020
13. ■ Isacord 40 0020
14. ■ Isacord 40 0020

12736-08 136 x 140 mm
5.3 x 5.5 inch 1.407

1. ■ Isacord 40 0020
2. ■ Isacord 40 0020
3. ■ Isacord 40 0020
4. ■ Isacord 40 0020
5. ■ Isacord 40 0020
6. ■ Isacord 40 0020
7. ■ Isacord 40 0020
8. ■ Isacord 40 0020

12736-09 140 x 140 mm
5.5 x 5.5 inch 1.624

1. ■ Isacord 40 0020
2. ■ Isacord 40 0020
3. ■ Isacord 40 0020
4. ■ Isacord 40 0020
5. ■ Isacord 40 0020
6. ■ Isacord 40 0020
7. ■ Isacord 40 0020
8. ■ Isacord 40 0020
9. ■ Isacord 40 0020
10. ■ Isacord 40 0020

12736-10 137 x 137 mm
5.4 x 5.4 inch 1.240

1. ■ Isacord 40 0020

12736-11 152 x 152 mm
6 x 6 inch 1.181

1. ■ Isacord 40 0020

12736-12 127 x 127 mm
5 x 5 inch 966














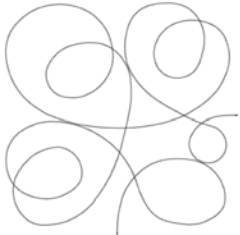

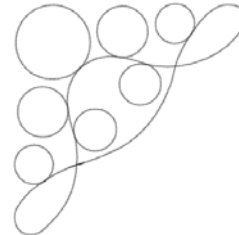
1. ■ Isacord 40 0020

12736-13 152 x 152 mm
6 x 6 inch 878

1. ■ Isacord 40 0020




























12736-14 126 x 126 mm
4.9 x 4.9 inch 653

1. ■ Isacord 40 0020

12736-15  127 x 126 mm 5 x 4.9 inch  728	12736-16  127 x 127 mm 5 x 5 inch  716
1.  Isacord 40 0020 	1.  Isacord 40 0020 
12736-17  127 x 127 mm 5 x 5 inch  629	12736-18  112 x 112 mm 4.4 x 4.4 inch  464
1.  Isacord 40 0020 	1.  Isacord 40 0020 





















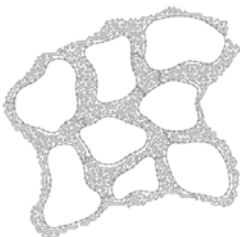
Projects

You can find the detailed embroidery instructions at <https://www.bernina.com/770PLUSdesigns>.








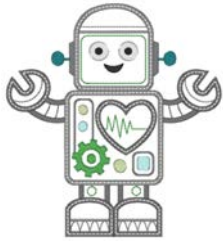
32152-01  150 x 229 mm 5.9 x 9 inch  7.265	32152-02  100 x 135 mm 3.9 x 5.3 inch  1.356
1.  Isacord 40 0108 	1.  Isacord 40 0108 
32152-03a  188 x 220 mm 7.4 x 8.7 inch  1.803	32152-03b  179 x 196 mm 7.1 x 7.7 inch  1.847
1.  Isacord 40 0108 2.  Isacord 40 0108 	1.  Isacord 40 0108 2.  Isacord 40 0108 
32152-04  190 x 288 mm 7.5 x 11.4 inch  22.113	32152-05a  190 x 153 mm 7.5 x 6 inch  10.319
1.  Isacord 40 0108 	1.  Isacord 40 0108 2.  Isacord 40 0108 




Overview Stitch Patterns

32152-05b	 184 x 176 mm 7.2 x 6.9 inch	 11.845	32152-06	 115 x 140 mm 4.5 x 5.5 inch	 2.532
1. ■ Isacord 40 0108 2. ■ Isacord 40 0108 3. ■ Isacord 40 0108			1. ■ Isacord 40 0108		
32152-07	 115 x 140 mm 4.5 x 5.5 inch	 6.565	32152-08	 135 x 155 mm 5.3 x 6.1 inch	 2.473
1. ■ Isacord 40 0108			1. ■ Isacord 40 0108		
32152-09	 135 x 155 mm 5.3 x 6.1 inch	 7.220	32152-10	 190 x 279 mm 7.5 x 11 inch	 3.894
1. ■ Isacord 40 0108			1. ■ Isacord 40 0108		
32152-11	 125 x 122 mm 4.9 x 4.8 inch	 4.614			
1. ■ Isacord 40 0108					

Children


 Be790305	 118 x 145 mm 4.6 x 5.7 inch	 13.118	 12590-03	 135 x 147 mm 5.3 x 5.8 inch	 22.117
1. ■ Isacord 40 0015 2. ■ Applique 1 3. ■ Applique 3 4. ■ Isacord 40 3541 5. ■ Applique 1 6. ■ Applique 3 7. ■ Isacord 40 0345 8. ■ Applique 1 9. ■ Applique 3 10. ■ Isacord 40 1900			1. ■ Applique 1 2. ■ Applique 2 3. ■ Applique 1 4. ■ Applique 2 5. ■ Applique 1 6. ■ Applique 2 7. ■ Applique 1 8. ■ Applique 2 9. ■ Isacord 40 0015		
11. ■ Isacord 40 0020	12. ■ Isacord 40 0015	10. ■ Isacord 40 0020 13. ■ Isacord 40 4230 16. ■ Isacord 40 0112	11. ■ Isacord 40 5510 14. ■ Isacord 40 4116 17. ■ Isacord 40 0015	12. ■ Isacord 40 5650 15. ■ Isacord 40 0132	

Ck867 122 x 133 mm 4.8 x 5.2 inch 28.880




1. Applique 1
2. Applique 2
3. Applique 3
4. Isacord 40 5730
5. Isacord 40 2761
6. Isacord 40 0630
7. Isacord 40 3910
8. Isacord 40 0015
9. Isacord 40 0811
10. Isacord 40 2830
11. Isacord 40 4174
12. Isacord 40 1701
13. Isacord 40 3722
14. Isacord 40 0015
15. Isacord 40 1430

Cm031_48 86 x 64 mm 3.4 x 2.5 inch 6.433




1. Isacord 40 5730
2. Isacord 40 1352
3. Isacord 40 1755
4. Isacord 40 1730
5. Isacord 40 3820
6. Isacord 40 3040

12401-17 99 x 55 mm 3.9 x 2.2 inch 1.345




1. Isacord 40 0731
2. Isacord 40 0630
3. Isacord 40 5934
4. Isacord 40 0111
5. Isacord 40 4240
6. Isacord 40 1342

Ck859 119 x 142 mm 4.7 x 5.6 inch 30.121




1. Isacord 40 3815
2. Isacord 40 0101
3. Isacord 40 6141
4. Isacord 40 0630
5. Isacord 40 3910
6. Isacord 40 0811
7. Isacord 40 0015
8. Isacord 40 0904
9. Isacord 40 3241
10. Isacord 40 1701
11. Isacord 40 4174
12. Isacord 40 3815
13. Isacord 40 0015
14. Isacord 40 2153

Ck520 75 x 60 mm 3 x 2.4 inch 11.019




1. Isacord 40 3906
2. Isacord 40 0132
3. Isacord 40 0015
4. Yenmet 7003
5. Isacord 40 3652
6. Isacord 40 0020
7. Isacord 40 0600
8. Isacord 40 2113

Ck510 76 x 60 mm 3 x 2.4 inch 8.069




1. Isacord 40 5934
2. Isacord 40 3840
3. Isacord 40 3901
4. Isacord 40 0108
5. Isacord 40 0015
6. Isacord 40 3622
7. Isacord 40 4174
8. Isacord 40 0015

Ck522 71 x 53 mm 2.8 x 2.1 inch 9.089




1. Isacord 40 3810
2. Isacord 40 0131
3. Isacord 40 0015
4. Isacord 40 0020
5. Isacord 40 0310
6. Isacord 40 1703
7. Yenmet 7021
8. Isacord 40 3353

Ck863 127 x 125 mm 5 x 4.9 inch 19.354



1. Isacord 40 0630
2. Isacord 40 0506
3. Isacord 40 0630
4. Isacord 40 0015
5. Isacord 40 4103
6. Isacord 40 4111
7. Isacord 40 1701
8. Isacord 40 2830
9. Isacord 40 5912
10. Isacord 40 1730
11. Isacord 40 5510
12. Isacord 40 0811
13. Isacord 40 4174
14. Isacord 40 0352
15. Isacord 40 1805
16. Isacord 40 0015
17. Isacord 40 3151

Nb198_48 94 x 72 mm 3.7 x 2.8 inch 9.711











1. Isacord 40 2650
2. Isacord 40 0713
3. Isacord 40 2166
4. Isacord 40 1755
5. Isacord 40 3251
6. Isacord 40 1600
7. Isacord 40 2153
8. Isacord 40 2152
9. Isacord 40 2761



































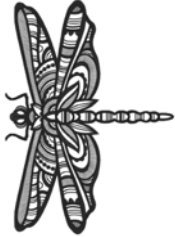































































Cm226_48 63 x 63 mm 2.5 x 2.5 inch 6.214



1. Isacord 40 0101
2. Isacord 40 0131
3. Isacord 40 0152
4. Isacord 40 0020
5. Isacord 40 1755

<p>Be790307</p>	<p>142 x 127 mm 5.6 x 5 inch</p>	<p>19.667</p>	<ol style="list-style-type: none"> 1. Applique 1 2. Applique 3 3. Isacord 40 3130 4. Applique 1 5. Applique 3 6. Isacord 40 0003 7. Isacord 40 1720 8. Isacord 40 0020 9. Isacord 40 0520 10. Isacord 40 3541 		<p>Be790311</p> <p>114 x 152 mm 4.5 x 6 inch</p> <p>12.320</p> <ol style="list-style-type: none"> 1. Applique 1 2. Applique 3 3. Isacord 40 0933 4. Applique 1 5. Applique 3 6. Applique 1 7. Applique 3 8. Isacord 40 0776 9. Applique 1 10. Applique 3 11. Isacord 40 1900 12. Isacord 40 0176 13. Isacord 40 0015 14. Isacord 40 0020 	
<p>Be790306</p>	<p>132 x 151 mm 5.2 x 6 inch</p>	<p>18.399</p>	<ol style="list-style-type: none"> 1. Isacord 40 0003 2. Applique 1 3. Applique 2 4. Isacord 40 0003 5. Isacord 40 3910 6. Isacord 40 0230 7. Isacord 40 2723 8. Isacord 40 1301 9. Isacord 40 2640 10. Isacord 40 0003 11. Isacord 40 3332 		<p>Be790308</p> <p>155 x 178 mm 6.1 x 7 inch</p> <p>25.448</p> <ol style="list-style-type: none"> 1. Isacord 40 0020 2. Applique 1 3. Applique 2 4. Isacord 40 1720 	
<p>Be790309</p>	<p>87 x 150 mm 3.4 x 5.9 inch</p>	<p>13.252</p>	<ol style="list-style-type: none"> 1. Applique 1 2. Applique 3 3. Isacord 40 0015 4. Isacord 40 1900 5. Isacord 40 0020 6. Isacord 40 4116 7. Isacord 40 0176 8. Isacord 40 0015 9. Isacord 40 0310 		<p>Be790310</p> <p>138 x 136 mm 5.4 x 5.4 inch</p> <p>16.278</p> <ol style="list-style-type: none"> 1. Applique 1 2. Applique 3 3. Applique 1 4. Applique 3 5. Isacord 40 1161 6. Isacord 40 1141 7. Isacord 40 1161 8. Isacord 40 3654 9. Isacord 40 0176 10. Isacord 40 1141 11. Isacord 40 0020 12. Isacord 40 0015 13. Isacord 40 1900 	
<p>Be790312</p>	<p>122 x 133 mm 4.8 x 5.2 inch</p>	<p>22.489</p>	<ol style="list-style-type: none"> 1. Applique 1 2. Applique 3 3. Applique 1 4. Applique 3 5. Isacord 40 0015 6. Isacord 40 1600 7. Isacord 40 0108 8. Isacord 40 2912 9. Isacord 40 3600 10. Isacord 40 1141 11. Isacord 40 0020 		<p>Be790313</p> <p>99 x 102 mm 3.9 x 4 inch</p> <p>8.788</p> <ol style="list-style-type: none"> 1. Applique 1 2. Applique 3 3. Isacord 40 3750 4. Isacord 40 1114 5. Isacord 40 1900 6. Isacord 40 3620 7. Isacord 40 2510 8. Isacord 40 5324 9. Isacord 40 1114 10. Isacord 40 1060 11. Isacord 40 4114 12. Isacord 40 0020 	

Animals

12676-01	 81 x 148 mm 3.2 x 5.8 inch	 15.344	<ol style="list-style-type: none"> 1.  Isacord 40 2171 2.  Isacord 40 2530 3.  Isacord 40 2155 4.  Isacord 40 2520 5.  Isacord 40 2500 		Cm263_48	 116 x 192 mm 4.6 x 7.6 inch	 14.402	<ol style="list-style-type: none"> 1.  Isacord 40 3151 2.  Isacord 40 0532 3.  Isacord 40 1755 4.  Isacord 40 2171 5.  Isacord 40 2761 6.  Isacord 40 0015 7.  Isacord 40 0020 8.  Isacord 40 2155 	
12389-10	 53 x 45 mm 2.1 x 1.8 inch	 2.784	<ol style="list-style-type: none"> 1.  Isacord 40 0020 2.  Yenmet 7003 3.  Isacord 40 0170 4.  Isacord 40 0811 5.  Isacord 40 0940 6.  Isacord 40 0800 7.  Isacord 40 0713 8.  Isacord 40 0933 9.  Isacord 40 0020 		12760-02	 122 x 171 mm 4.8 x 6.7 inch	 21.512	<ol style="list-style-type: none"> 1.  Isacord 40 0020 	
Wp415_48	 132 x 148 mm 5.2 x 5.8 inch	 25.110	<ol style="list-style-type: none"> 1.  Isacord 40 0941 2.  Isacord 40 0532 3.  Isacord 40 0945 4.  Isacord 40 0020 		 Cm216_48	 47 x 67 mm 1.9 x 2.6 inch	 5.046	<ol style="list-style-type: none"> 1.  Isacord 40 1010 2.  Isacord 40 0101 3.  Isacord 40 0132 4.  Isacord 40 0020 5.  Isacord 40 0124 6.  Isacord 40 1010 7.  YLI variations 8012 	
 Cm213_48	 58 x 102 mm 2.3 x 4 inch	 7.866	<ol style="list-style-type: none"> 1.  Isacord 40 1840 2.  Isacord 40 1055 3.  Isacord 40 1252 4.  Isacord 40 0651 5.  Isacord 40 0660 6.  Isacord 40 0020 7.  Isacord 40 1055 		Wp421_48	 96 x 137 mm 3.8 x 5.4 inch	 14.219	<ol style="list-style-type: none"> 1.  Isacord 40 1161 2.  Isacord 40 1876 3.  Isacord 40 1154 	
Na248	 78 x 73 mm 3.1 x 2.9 inch	 10.132	<ol style="list-style-type: none"> 1.  Isacord 40 0101 2.  Isacord 40 3971 3.  Isacord 40 2220 4.  Isacord 40 0132 5.  Isacord 40 2051 6.  Isacord 40 2155 7.  Isacord 40 2320 8.  Isacord 40 2220 9.  Yenmet 7023 		Hd977	 98 x 98 mm 3.8 x 3.9 inch	 13.738	<ol style="list-style-type: none"> 1.  Isacord 40 3962 2.  Isacord 40 0015 3.  Isacord 40 0640 4.  Isacord 40 0824 5.  Isacord 40 2650 6.  Isacord 40 0020 7.  Isacord 40 0142 8.  Isacord 40 0640 9.  Isacord 40 0824 10.  Isacord 40 2650 11.  Isacord 40 2830 12.  Isacord 40 1352 13.  Yenmet 7029 	

Lj598



106 x 81 mm
4.2 x 3.2 inch



15.746

1. Isacord 40 0101
2. Isacord 40 0131
3. Isacord 40 0132
4. Isacord 40 4174
5. Isacord 40 0108
6. Isacord 40 0020
7. Isacord 40 5933
8. Isacord 40 0453



Borders



12383-09

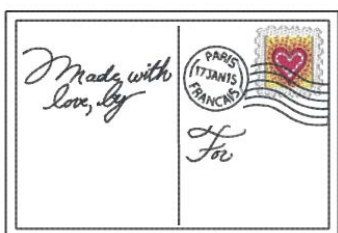


113 x 77 mm
4.4 x 3 inch



4.757

1. Isacord 40 0020
2. Isacord 40 4174
3. Isacord 40 0608
4. Isacord 40 2101
5. Isacord 40 1600
6. Isacord 40 0015
7. Isacord 40 4174



12621-19

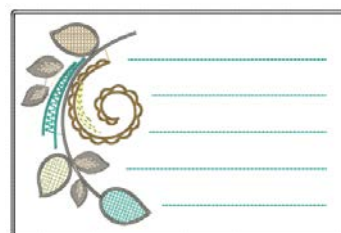


155 x 104 mm
6.1 x 4.1 inch



8.360

1. Isacord 40 0015
2. Isacord 40 0015
3. Isacord 40 0721
4. Isacord 40 4620
5. Isacord 40 0352
6. Isacord 40 0152
7. Isacord 40 0672
8. Isacord 40 4620
9. Isacord 40 0015



12621-04

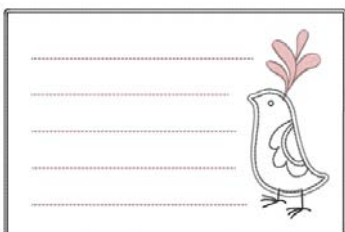


155 x 104 mm
6.1 x 4.1 inch



3.803

1. Isacord 40 0015
2. Isacord 40 0015
3. Isacord 40 0020
4. Isacord 40 2051
5. Isacord 40 0015
6. Isacord 40 4174
7. Isacord 40 2051
8. Isacord 40 0015



12621-05



155 x 104 mm
6.1 x 4.1 inch



5.811

1. Isacord 40 0015
2. Isacord 40 0015
3. Isacord 40 0933
4. Isacord 40 1252
5. Isacord 40 1252
6. Isacord 40 0015



12621-09

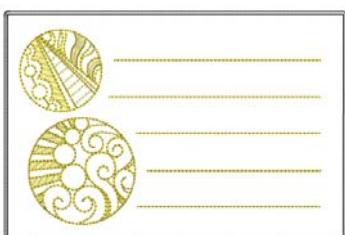


155 x 104 mm
6.1 x 4.1 inch



5.520

1. Isacord 40 0015
2. Isacord 40 0015
3. Isacord 40 0504
4. Isacord 40 0542
5. Isacord 40 0542
6. Isacord 40 0015



12621-02

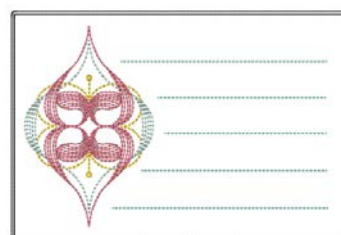


155 x 104 mm
6.1 x 4.1 inch



5.558

1. Isacord 40 0020
2. Isacord 40 0020
3. Isacord 40 0811
4. Isacord 40 4952
5. Isacord 40 1921
6. Isacord 40 4952
7. Isacord 40 0020



80090-26



124 x 129 mm
4.9 x 5.1 inch



6.087

1. Applique 1
2. Applique 2
3. Applique 1
4. Applique 2
5. Isacord 40 4103
6. Isacord 40 2508



12611-27

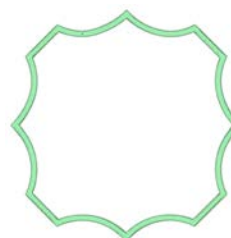


137 x 137 mm
5.4 x 5.4 inch




3.961

1. Applique 1
2. Applique 2
3. Isacord 40 5440




12611-28 140 x 140 mm
5.5 x 5.5 inch 3.649

1. Applique 1
2. Applique 2
3. Isacord 40 0703




12649-05 91 x 88 mm
3.6 x 3.5 inch 9.087

1. Applique 1
2. Applique 2
3. Isacord 40 1840
4. Isacord 40 1860
5. Isacord 40 0015




12606-26 139 x 139 mm
5.5 x 5.5 inch 5.211

1. Isacord 40 0670
2. Isacord 40 0670
3. Isacord 40 0670




12606-33 43 x 70 mm
1.7 x 2.8 inch 2.376

1. Isacord 40 0670
2. Isacord 40 0670
3. Isacord 40 0670



12606-37 46 x 78 mm
1.8 x 3.1 inch 2.692

1. Isacord 40 0670
2. Isacord 40 0670
3. Isacord 40 0670



12611-21 156 x 72 mm
6.1 x 2.8 inch 11.513

1. Applique 1
2. Applique 2
3. Isacord 40 1703



12611-23 156 x 72 mm
6.1 x 2.8 inch 12.817

1. Applique 1
2. Applique 2
3. Isacord 40 1902



12611-22 156 x 72 mm
6.1 x 2.8 inch 12.504

1. Applique 1
2. Applique 2
3. Isacord 40 1703



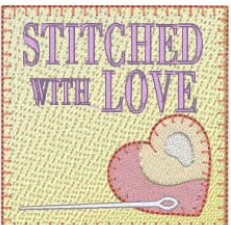
12611-24 156 x 72 mm
6.1 x 2.8 inch 12.613

1. Applique 1
2. Applique 2
3. Isacord 40 1902













Nz195 77 x 77 mm
3 x 3 inch 15.343

1. Isacord 40 0660
2. Isacord 40 0713
3. Isacord 40 2153
4. Isacord 40 1362
5. Isacord 40 0870
6. Isacord 40 2830
7. Isacord 40 1725
8. Isacord 40 4071









Nx763  87 x 72 mm
3.4 x 2.8 inch  14.953

1.  Isacord 40 2155
2.  Isacord 40 0520
3.  Isacord 40 1921
4.  Isacord 40 5912
5.  Isacord 40 5510
6.  Isacord 40 3040
7.  Isacord 40 0310
8.  Isacord 40 3910
9.  Isacord 40 0442
10.  Isacord 40 2830










Sport and hobbies

 **82014-28**  142 x 117 mm
5.6 x 4.6 inch  26.582



1.  Applique 1
2.  Applique 2
3.  Isacord 40 0105
4.  Isacord 40 0020
5.  Isacord 40 4073
6.  Isacord 40 1902







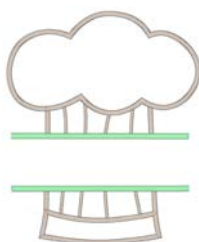
 **12611-08**  80 x 120 mm
3.1 x 4.7 inch  5.770



1.  Applique 1
2.  Applique 2
3.  Applique 1
4.  Applique 2
5.  Isacord 40 1154
6.  Isacord 40 5440
7.  Isacord 40 1902






 **12611-18**  130 x 158 mm
5.1 x 6.2 inch  8.045



1.  Applique 1
2.  Applique 2
3.  Isacord 40 0151
4.  Isacord 40 5440











Nx737  72 x 99 mm
2.8 x 3.9 inch  10.793



1. Isacord 40 0015
2.  Yenmet 7005
3.  Isacord 40 3962
4.  Isacord 40 0020



Nx741  80 x 78 mm
3.1 x 3.1 inch  11.206

1.  Isacord 40 0131
2.  Isacord 40 0111
3.  Isacord 40 0970
4. Isacord 40 0015
5.  Isacord 40 3971
6.  Yenmet 7009
7.  Yenmet 7003
8.  Isacord 40 4230
9.  Isacord 40 4174















12383-18  91 x 171 mm
3.6 x 6.7 inch  5.182

1.  Isacord 40 4174





 **12472-01**  138 x 142 mm
5.4 x 5.6 inch  23.233



1.  Isacord 40 2504
2.  Isacord 40 3901
3.  Isacord 40 5610
4.  Isacord 40 4240
5. Isacord 40 0015
6. Isacord 40 0015
7.  Isacord 40 1123
8.  Isacord 40 0761
9.  Isacord 40 1902
10.  Isacord 40 2504
11.  Isacord 40 3901
12.  Isacord 40 5610
13.  Isacord 40 4240
14.  Isacord 40 1300




Be790606  100 x 86 mm
3.9 x 3.4 inch  7.445



1.  Isacord 40 0020
2.  Isacord 40 1306




Be790608  80 x 80 mm
3.2 x 3.1 inch  7.937

1.  Isacord 40 0020





Be790603  80 x 75 mm
3.2 x 2.9 inch  11.824

1. Isacord 40 0015
2.  Isacord 40 3654













Be790602  80 x 75 mm
3.1 x 3 inch  10.169

1.  Isacord 40 5643
2.  Isacord 40 5912
3. Isacord 40 0015







Embellishment

Nb843_48  87 x 121 mm
3.4 x 4.8 inch  8.976



1.  Isacord 40 9971
2.  Isacord 40 9937
3.  Isacord 40 9925
4.  Isacord 40 9975
5.  Isacord 40 9978
6.  Isacord 40 9973
7.  Isacord 40 9982
8.  Isacord 40 1972



Nb826_48  135 x 133 mm
5.3 x 5.2 inch  11.154



1.  Isacord 40 9971
2.  Isacord 40 9978
3.  Isacord 40 9973
4.  Isacord 40 1972





12633-06  120 x 120 mm
4.7 x 4.7 inch  18.023

1. Isacord 40 0015





12473-04  94 x 184 mm
3.7 x 7.3 inch  11.531


1.  Isacord 40 5552
2.  Isacord 40 5374





Be790403  140 x 130 mm
5.5 x 5.1 inch  13.281

1.  Isacord 40 0020
2.  Isacord 40 0731



12473-06  133 x 120 mm
5.3 x 4.7 inch  11.358

1.  Isacord 40 4610
2.  Isacord 40 5633



80090-06

84 x 37 mm
3.3 x 1.4 inch

3.766

1. Applique 1
2. Applique 2
3. Isacord 40 4103



80090-07

128 x 36 mm
5 x 1.4 inch

5.450

1. Applique 1
2. Applique 2
3. Isacord 40 5440



19999-002

125 x 136 mm
4.9 x 5.4 inch

10.184

1. Isacord 40 0015
2. Isacord 40 0015
3. Isacord 40 0015



Nb934_48

132 x 165 mm
5.2 x 6.5 inch

9.168

1. Isacord 40 2241
2. Isacord 40 1154
3. Isacord 40 1346
4. Isacord 40 1161
5. Isacord 40 2222
6. Isacord 40 5833
7. Isacord 40 1154
8. Isacord 40 2241



Nb935_48

104 x 169 mm
4.1 x 6.6 inch

10.171

1. Isacord 40 2222
2. Isacord 40 1346
3. Isacord 40 0232
4. Isacord 40 1154
5. Isacord 40 5833
6. Isacord 40 2241



21021-05

119 x 156 mm
4.7 x 6.1 inch

14.326

1. Isacord 40 1252
2. Isacord 40 1161
3. Isacord 40 1565



21021-04

123 x 150 mm
4.8 x 5.9 inch

16.176

1. Isacord 40 1161
2. Isacord 40 1252
3. Isacord 40 1565



21021-06

116 x 109 mm
4.6 x 4.3 inch

12.204

1. Isacord 40 1161
2. Isacord 40 1252
3. Isacord 40 1565



12490-03

118 x 113 mm
4.6 x 4.5 inch

6.669

1. Isacord 40 0108
2. Isacord 40 3641
3. Isacord 40 3652



12490-04

146 x 122 mm
5.8 x 4.8 inch

8.724

1. Isacord 40 0108
2. Isacord 40 3641
3. Isacord 40 3652



12490-05

126 x 104 mm
4.9 x 4.1 inch

6.148

1. Isacord 40 0108
2. Isacord 40 3641
3. Isacord 40 3652





Fp887




135 x 187 mm
5.3 x 7.4 inch

12.658



1. Isacord 40 2504






12528-12  124 x 124 mm
4.9 x 4.9 inch  39.751

1.  Isacord 40 0931
2.  Isacord 40 0824
3.  Isacord 40 0851






12528-03  76 x 130 mm
3 x 5.1 inch  16.171

1.  Isacord 40 0851
2.  Isacord 40 0824
3.  Isacord 40 0931














Oc07207  106 x 138 mm
4.2 x 5.4 inch  17.807

1.  Yenmet 7012
2.  Isacord 40 0670
3.  Yenmet 7012





82007-11  112 x 94 mm
4.4 x 3.7 inch  13.622

1.  Applique 1
2.  Applique 3
3.  Applique 1
4.  Applique 3
5.  Applique 1
6.  Isacord 40 1805
7.  Isacord 40 2152
8.  Isacord 40 2520
9.  Isacord 40 2500
10.  Isacord 40 2115
11.  Isacord 40 0761













82007-44  114 x 115 mm
4.5 x 4.5 inch  9.467



1.  Isacord 40 2152
2.  Isacord 40 2520







82006-30  100 x 174 mm
3.9 x 6.9 inch  21.584


1.  Isacord 40 0020
2.  Isacord 40 4174
3.  Isacord 40 0020
4.  Isacord 40 4174
5.  Isacord 40 0771
6.  Isacord 40 0832
7.  Isacord 40 0108
8.  Isacord 40 4174
9.  Isacord 40 0660
10.  Isacord 40 1526



Nb251_48  72 x 103 mm
2.8 x 4.1 inch  8.612



1.  Isacord 40 2155
2.  Isacord 40 2504
3.  Isacord 40 0020
4.  Isacord 40 0020





Be790405  126 x 185 mm
4.9 x 7.3 inch  7.734

1.  Isacord 40 3102



Fb126  87 x 102 mm
3.4 x 4 inch  2.668

1.  Isacord 40 1220
2.  Isacord 40 1805



Be790407  200 x 271 mm
7.9 x 10.7 inch  19.455

1.  Isacord 40 2510



Be790502



60 x 58 mm
2.4 x 2.3 inch



1.814

1. Isacord 40 3541



Borders and Lace



12659-01



45 x 58 mm
1.8 x 2.3 inch



6.790

1. Isacord 40 1352
2. Isacord 40 1430



12659-06



37 x 59 mm
1.4 x 2.3 inch



6.465

1. Isacord 40 4625
2. Isacord 40 4515



21021-25



34 x 71 mm
1.3 x 2.8 inch



4.748

1. Isacord 40 1252



Oc00303



101 x 110 mm
4 x 4.4 inch



35.018

1. Isacord 40 0015



12633-20



34 x 170 mm
1.4 x 6.7 inch



12.897

1. Isacord 40 0015



12508-08



40 x 151 mm
1.6 x 5.9 inch



7.102

1. Isacord 40 0352
2. Isacord 40 4752
3. Isacord 40 0124



12508-17



42 x 152 mm
1.6 x 6 inch



7.962

1. Isacord 40 0352
2. Isacord 40 4752
3. Isacord 40 5552



Oc33411































































24 x 177 mm
0.9 x 7 inch







15.868

1. Isacord 40 0015



<p>Oc33416  36 x 128 mm 1.4 x 5 inch  16.090</p>	<p>12485-12  41 x 139 mm 1.6 x 5.5 inch  3.391</p>
<p>1.  Isacord 40 1902 2.  Isacord 40 0015</p> 	<p>1.  Isacord 40 1134 2.  Isacord 40 0520 3.  Isacord 40 4240 4.  Isacord 40 4111 5.  Isacord 40 0702 6.  Isacord 40 1430</p> 
<p>12485-31  46 x 225 mm 1.8 x 8.9 inch  2.174</p>	<p>21013-29  40 x 152 mm 1.6 x 6 inch  7.569</p>
<p>1.  Isacord 40 0702 2.  Isacord 40 0520</p> 	<p>1.  Isacord 40 4332</p> 
<p>Be110415  44 x 172 mm 1.7 x 6.8 inch  6.436</p>	<p>Fa981  35 x 142 mm 1.4 x 5.6 inch  3.709</p>
<p>1.  Isacord 40 6051 2.  Isacord 40 0811 3.  Isacord 40 1921</p> 	<p>1.  Isacord 40 1055</p> 
<p>21002-21  21 x 151 mm 0.8 x 5.9 inch  3.176</p>	<p>21009-29  32 x 152 mm 1.3 x 6 inch  4.649</p>
<p>1.  Isacord 40 1252</p> 	<p>1.  Isacord 40 5210</p> 
<p>82005-40  26 x 240 mm 1 x 9.4 inch  8.256</p>	<p>Be790702  73 x 190 mm 2.9 x 7.5 inch  9.135</p>
<p>1.  Isacord 40 0851</p> 	<p>1.  Isacord 40 0442</p> 
<p>Na914_48  19 x 120 mm 0.7 x 4.7 inch  4.691</p>	<p>Cm473_48  32 x 209 mm 1.2 x 8.2 inch  8.963</p>
<p>1.  Isacord 40 3151 2.  Isacord 40 3251 3.  Isacord 40 3150</p> 	<p>1.  Isacord 40 3920 2.  Isacord 40 3962</p> 










Fb436_48  29 x 133 mm
1.1 x 5.2 inch  4.735

1.  Isacord 40 3130
2.  Isacord 40 3150
3.  Isacord 40 4240









Seasons

 **82023-14**  119 x 123 mm
4.7 x 4.8 inch  14.989

1.  Isacord 40 1753
2.  Isacord 40 1753
3.  Isacord 40 1753
4.  Isacord 40 0010
5.  Isacord 40 5100
6.  Isacord 40 5210
7.  Isacord 40 5220
8.  Isacord 40 2101
9.  Isacord 40 1753









82023-15  124 x 152 mm
4.9 x 6 inch  9.577



1.  Isacord 40 5210
2.  Isacord 40 5220
3.  Isacord 40 5100
4.  Isacord 40 1805
5.  Isacord 40 2101
6.  Isacord 40 1753









82023-13  106 x 156 mm
4.2 x 6.1 inch  11.315


1.  Isacord 40 5220
2.  Isacord 40 1753
3.  Isacord 40 1805
4.  Isacord 40 2101
5.  Isacord 40 5210
6.  Isacord 40 5100





Hg795_48  89 x 164 mm
3.5 x 6.5 inch  3.453

1.  Isacord 40 5730
2.  Isacord 40 5513
3.  Isacord 40 4430
4.  Isacord 40 1032
5.  Isacord 40 1900
6.  Isacord 40 4113





 **12597-16**  88 x 85 mm
3.5 x 3.3 inch  15.862

1.  Isacord 40 0904
2.  Isacord 40 0940






12858-04  159 x 164 mm
6.3 x 6.4 inch  16.385

1.  Isacord 40 0015
2.  Isacord 40 0015
























80009-17  86 x 130 mm
3.4 x 5.1 inch  6.582

1.  Isacord 40 5934
2.  Isacord 40 5866
3.  Isacord 40 5934




 **He255**  133 x 127 mm
5.2 x 5 inch  17.198

1.  Isacord 40 0111
2.  Isacord 40 1701
3.  Isacord 40 1800
4.  Isacord 40 1701
5.  Isacord 40 1800
6.  Isacord 40 2640
7.  Isacord 40 5650
8.  Isacord 40 5610
9.  Isacord 40 0015
10.  Isacord 40 0111
11.  Isacord 40 1060
12.  Isacord 40 3910
13.  Isacord 40 0800
14.  Isacord 40 0940
15.  Isacord 40 0651
16.  Isacord 40 0832
17.  Isacord 40 0651
18.  Isacord 40 0832
19.  Isacord 40 3650
20.  Isacord 40 1351
21.  Isacord 40 0108




He252 88 x 145 mm 3.5 x 5.7 inch 12.251




1. Isacord 40 1902
2. Isacord 40 1701
3. Isacord 40 1902
4. Isacord 40 0532
5. Isacord 40 0842
6. Isacord 40 0532
7. Isacord 40 0842
8. Isacord 40 1902
9. Isacord 40 0651
10. Isacord 40 1123
11. Isacord 40 5220
12. Isacord 40 5210
13. Isacord 40 5422
14. Isacord 40 0101
15. Isacord 40 1430
16. Isacord 40 1725
17. Isacord 40 0520
18. Isacord 40 0824
19. Isacord 40 3910
20. Isacord 40 3650
21. Isacord 40 3910
22. Isacord 40 1902
23. Isacord 40 3650
24. Isacord 40 1123
25. Isacord 40 5324
26. Isacord 40 1154

Hg746_48 112 x 138 mm 4.4 x 5.4 inch 17.815




1. Isacord 40 3040
2. Applique 1
3. Applique 2
4. Isacord 40 0221
5. Applique 1
6. Applique 2
7. Isacord 40 0142
8. Isacord 40 0108
9. Applique 1
10. Applique 2
11. Isacord 40 0800
12. Isacord 40 0020
13. Isacord 40 1200
14. Isacord 40 0020
15. Isacord 40 0670
16. Isacord 40 0142

Rc514 74 x 99 mm 2.9 x 3.9 inch 15.603




1. Isacord 40 1172
2. Isacord 40 0842
3. Isacord 40 0651
4. Isacord 40 0821
5. Isacord 40 0941
6. Isacord 40 0101
7. Isacord 40 0640
8. Isacord 40 3910
9. Isacord 40 4103
10. Isacord 40 3522
11. Isacord 40 0842

Hg747_48 124 x 147 mm 4.9 x 5.8 inch 18.378




1. Isacord 40 0970
2. Isacord 40 3770
3. Isacord 40 5912
4. Isacord 40 0520
5. Isacord 40 0811
6. Isacord 40 3350
7. Isacord 40 3040
8. Applique 1
9. Applique 2
10. Applique 1
11. Applique 2
12. Applique 1
13. Applique 2
14. Isacord 40 4073
15. Isacord 40 0020
16. Isacord 40 1200
17. Isacord 40 0101

Nb754_48 114 x 128 mm 4.5 x 5 inch 13.084




1. Yenmet 7037
2. Isacord 40 2155
3. Isacord 40 0651
4. Isacord 40 0101
5. Isacord 40 2532
6. Isacord 40 0640
7. Isacord 40 1352
8. Yenmet 7030
9. Isacord 40 0232
10. Isacord 40 1123

Nb759_48 99 x 62 mm 3.9 x 2.4 inch 4.937




1. Yenmet 7037
2. Isacord 40 0640
3. Isacord 40 1352
4. Isacord 40 0232
5. Isacord 40 1123

Hd976 101 x 108 mm 4 x 4.3 inch 18.674































































1. Isacord 40 3962
2. Yenmet 7029
3. Isacord 40 0640
4. Isacord 40 0824
5. Isacord 40 0015
6. Isacord 40 0020
7. Isacord 40 0142
8. Isacord 40 3962
9. Isacord 40 0020
10. Isacord 40 0934
11. Isacord 40 0640
12. Isacord 40 0824
13. Isacord 40 5650
14. Isacord 40 5531
15. Isacord 40 1220
16. Isacord 40 5822
17. Isacord 40 5531
18. Isacord 40 0015
19. Isacord 40 5822

Hg806_48 28 x 170 mm 1.1 x 6.7 inch 4.988






















































































































































































































1. Isacord 40 2530
2. Isacord 40 1900
3. Isacord 40 5730
4. Isacord 40 1114
5. Isacord 40 4430
6. Isacord 40 4113

























Overview Stitch Patterns

<p>12415-32  80 x 191 mm 3.1 x 7.5 inch  10.937</p>	<p>12415-29  108 x 172 mm 4.3 x 6.8 inch  4.814</p>
<p>1.  YLI variations 8019</p> 	<p>1.  YLI variations 8019</p> 
<p>12655-14  164 x 110 mm 6.4 x 4.4 inch  16.122</p>	<p> 12433-05  83 x 124 mm 3.3 x 4.9 inch  15.348</p>
<p>1.  Isacord 40 1115 2.  Isacord 40 1055</p> 	<p>1.  Isacord 40 1725 2.  Isacord 40 5934 3.  Isacord 40 0442 4.  Isacord 40 2115 5.  Isacord 40 2711</p> 
<p>12417-04  84 x 97 mm 3.3 x 3.8 inch  8.085</p>	<p>Be790303  70 x 70 mm 2.7 x 2.8 inch  5.764</p>
<p>1.  Isacord 40 1010 2.  Isacord 40 0811 3.  Isacord 40 1311 4.  Isacord 40 1543</p> 	<p>1.  Isacord 40 0532 2.  Isacord 40 1300 3.  Isacord 40 0020 4.  Isacord 40 0015</p> 
<p>Be790301  127 x 89 mm 5 x 3.5 inch  10.153</p>	<p>12421-11  40 x 43 mm 1.6 x 1.7 inch  3.965</p>
<p>1.  Isacord 40 1161 2.  Isacord 40 1860 3.  Isacord 40 1805 4.  Isacord 40 4116 5.  Isacord 40 1114 6.  Isacord 40 0532 7.  Isacord 40 0731 8.  Isacord 40 1322 9.  Isacord 40 1141 10.  Isacord 40 0020</p> 	<p>1.  Isacord 40 0800 2.  Isacord 40 0904 3.  Isacord 40 0020 4.  Isacord 40 0015</p> 
<p>12421-37  67 x 61 mm 2.6 x 2.4 inch  1.320</p>	
<p>1.  Isacord 40 0020</p> 	




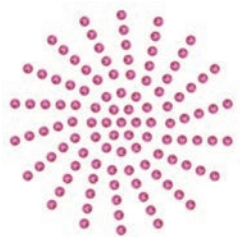




Flowers

Fq987_48	 119 x 160 mm 4.7 x 6.3 inch	 32.494	12505-03	 108 x 162 mm 4.3 x 6.4 inch	 8.606
<ol style="list-style-type: none"> 1.  Isacord 40 5650 2.  Isacord 40 5833 3.  Isacord 40 0352 4.  Isacord 40 5934 5.  Isacord 40 0465 6.  Isacord 40 0015 7.  Isacord 40 0781 8.  Isacord 40 0170 9.  Isacord 40 0731 10.  Isacord 40 0640 		<ol style="list-style-type: none"> 1.  Isacord 40 0442 2.  Isacord 40 5822 3.  Isacord 40 5822 4.  Isacord 40 6031 5.  Isacord 40 5633 6.  Isacord 40 2810 7.  Isacord 40 2530 8.  Isacord 40 2530 9.  Isacord 40 2155 10.  Isacord 40 0811 13.  Isacord 40 2830 16.  Isacord 40 0311 		<ol style="list-style-type: none"> 11.  Isacord 40 0811 12.  Isacord 40 2830 14.  Isacord 40 2504 15.  Isacord 40 4103 17.  Isacord 40 0931 18.  Isacord 40 0020 	
12505-11	 104 x 174 mm 4.1 x 6.9 inch	 11.419	12505-04	 124 x 176 mm 4.9 x 6.9 inch	 11.861
<ol style="list-style-type: none"> 1.  Isacord 40 0442 2.  Isacord 40 5822 3.  Isacord 40 5822 4.  Isacord 40 6031 5.  Isacord 40 5633 6.  Isacord 40 2810 7.  Isacord 40 2810 8.  Isacord 40 0811 9.  Isacord 40 0811 10.  Isacord 40 1800 13.  Isacord 40 0931 16.  Isacord 40 1912 		<ol style="list-style-type: none"> 1.  Isacord 40 3840 2.  Isacord 40 3840 3.  Isacord 40 3815 4.  Isacord 40 0311 5.  Isacord 40 5822 6.  Isacord 40 5822 7.  Isacord 40 6031 8.  Isacord 40 5633 9.  Isacord 40 0811 10.  Isacord 40 0811 13.  Isacord 40 2300 16.  Isacord 40 0504 		<ol style="list-style-type: none"> 11.  Isacord 40 2530 12.  Isacord 40 2530 14.  Isacord 40 2155 15.  Isacord 40 0931 17.  Isacord 40 0020 18.  Isacord 40 0442 	
12505-10	 102 x 134 mm 4 x 5.3 inch	 5.685	Fq472_48	 123 x 123 mm 4.8 x 4.8 inch	 4.361
<ol style="list-style-type: none"> 1.  Isacord 40 4103 2.  Isacord 40 0442 3.  Isacord 40 5822 4.  Isacord 40 5822 5.  Isacord 40 6031 6.  Isacord 40 5633 7.  Isacord 40 1800 8.  Isacord 40 1800 9.  Isacord 40 2504 10.  Isacord 40 0504 		<ol style="list-style-type: none"> 1.  Isacord 40 5610 2.  Isacord 40 2830 3.  Isacord 40 5822 4.  Isacord 40 5664 5.  Isacord 40 5643 6.  Isacord 40 0015 7.  Isacord 40 0811 8.  Isacord 40 5633 9.  Isacord 40 1725 			
Fq464_48	 110 x 104 mm 4.3 x 4.1 inch	 7.122	21027-01	 123 x 122 mm 4.8 x 4.8 inch	 6.211
<ol style="list-style-type: none"> 1.  Isacord 40 5822 2.  Isacord 40 5552 3.  Isacord 40 5650 4.  Isacord 40 1913 5.  Isacord 40 1725 6.  Isacord 40 2115 		<ol style="list-style-type: none"> 1.  Isacord 40 1805 2.  Isacord 40 2721 3.  Isacord 40 2520 4.  Isacord 40 5100 5.  Isacord 40 4114 6.  Isacord 40 4103 7.  Isacord 40 0506 8.  Isacord 40 5115 			

<p>21027-14  121 x 121 mm 4.8 x 4.8 inch  7.316</p> <ol style="list-style-type: none"> 1.  Isacord 40 5115 2.  Isacord 40 2721 3.  Isacord 40 4114 4.  Isacord 40 2520 5.  Isacord 40 0506 6.  Isacord 40 5100 7.  Isacord 40 1805 8.  Isacord 40 5115 9.  Isacord 40 1805 	<p>21027-16  57 x 152 mm 2.3 x 6 inch  4.222</p> <ol style="list-style-type: none"> 1.  Isacord 40 1805 2.  Isacord 40 2520 3.  Isacord 40 2721 4.  Isacord 40 5100 5.  Isacord 40 0506 6.  Isacord 40 5115 7.  Isacord 40 4114 8.  Isacord 40 5115 9.  Isacord 40 1805 
<p>21027-17  57 x 152 mm 2.3 x 6 inch  4.179</p> <ol style="list-style-type: none"> 1.  Isacord 40 1805 2.  Isacord 40 2721 3.  Isacord 40 2520 4.  Isacord 40 5100 5.  Isacord 40 0506 6.  Isacord 40 4103 7.  Isacord 40 4114 8.  Isacord 40 5115 9.  Isacord 40 1805 	<p>21017-01  104 x 158 mm 4.1 x 6.2 inch  11.928</p> <ol style="list-style-type: none"> 1.  Isacord 40 0453 2.  Isacord 40 0442 3.  Isacord 40 0345 4.  Isacord 40 1301 5.  Isacord 40 0702 6.  Isacord 40 1102 7.  Isacord 40 0761 8.  Isacord 40 0640 
<p>FI135  88 x 87 mm 3.5 x 3.4 inch  12.688</p> <ol style="list-style-type: none"> 1.  Isacord 40 5633 2.  Isacord 40 5822 3.  Isacord 40 5326 4.  Isacord 40 0870 5.  Isacord 40 3241 	<p>FI136  85 x 89 mm 3.3 x 3.5 inch  8.501</p> <ol style="list-style-type: none"> 1.  Isacord 40 0311 2.  Isacord 40 5326 3.  Isacord 40 5374 4.  Isacord 40 0101 5.  Isacord 40 3951 
<p>FI138  85 x 75 mm 3.3 x 3 inch  6.321</p> <ol style="list-style-type: none"> 1.  Isacord 40 5934 2.  Isacord 40 5633 3.  Isacord 40 3331 4.  Isacord 40 3211 5.  Isacord 40 5326 	<p>FI142  79 x 86 mm 3.1 x 3.4 inch  10.298</p> <ol style="list-style-type: none"> 1.  Isacord 40 2830 2.  Isacord 40 3541 3.  Isacord 40 2830 4.  Isacord 40 1912 5.  Isacord 40 0108 6.  Isacord 40 3842 7.  Isacord 40 0453 8.  Isacord 40 5326 
<p>FI230  78 x 72 mm 3.1 x 2.9 inch  6.959</p> <ol style="list-style-type: none"> 1.  Isacord 40 0600 2.  Isacord 40 5933 3.  Isacord 40 5944 	<p>FI171  70 x 89 mm 2.7 x 3.5 inch  11.783</p> <ol style="list-style-type: none"> 1.  Isacord 40 5100 2.  Isacord 40 5100 3.  Isacord 40 5326 4.  Isacord 40 2600 5.  Isacord 40 3040 

<p>82006-07  124 x 166 mm 4.9 x 6.5 inch  22.673</p> <ol style="list-style-type: none"> 1. Isacord 40 4174 2. Isacord 40 0108 3. Isacord 40 0643 4. Isacord 40 0660 5. Isacord 40 0643 6. Isacord 40 4421 7. Isacord 40 1526 8. Isacord 40 0660 9. Isacord 40 4174 	<p>21006-02  114 x 135 mm 4.5 x 5.3 inch  9.132</p> <ol style="list-style-type: none"> 1. Isacord 40 3910 2. Isacord 40 3900 3. Isacord 40 0015 4. Isacord 40 3962 5. Isacord 40 3900 6. Isacord 40 0015 
<p>80001-23  85 x 102 mm 3.4 x 4 inch  4.257</p> <ol style="list-style-type: none"> 1. Isacord 40 1102 2. Isacord 40 1805 3. Isacord 40 6011 4. Isacord 40 4174 	<p>12457-06  106 x 172 mm 4.2 x 6.8 inch  12.636</p> <ol style="list-style-type: none"> 1. Isacord 40 3150 2. Isacord 40 3210 3. Isacord 40 0311 4. Isacord 40 3331 5. Isacord 40 3711 6. Isacord 40 2250 7. Isacord 40 2241 8. Isacord 40 2051 
<p>12457-13  113 x 130 mm 4.4 x 5.1 inch  6.676</p> <ol style="list-style-type: none"> 1. Isacord 40 6051 2. Isacord 40 5730 3. Isacord 40 5722 4. Isacord 40 2905 5. Isacord 40 0311 6. Isacord 40 5115 7. Isacord 40 5220 8. Isacord 40 5100 	<p>21009-21  65 x 108 mm 2.6 x 4.2 inch  4.343</p> <ol style="list-style-type: none"> 1. Isacord 40 5220 2. Isacord 40 5210 
<p>Be790408  58 x 90 mm 2.3 x 3.5 inch  2.045</p> <ol style="list-style-type: none"> 1. Isacord 40 3541 	<p>Be790401  206 x 242 mm 8.1 x 9.5 inch  11.593</p> <ol style="list-style-type: none"> 1. Isacord 40 1900 

DesignWorks

<p> Dw11  70 x 71 mm 2.8 x 2.8 inch  110</p> <ol style="list-style-type: none"> 1. Swarovski 0502 	<p> 21026-08_dw  86 x 174 mm 3.4 x 6.9 inch  11.047</p> <ol style="list-style-type: none"> 1. Edding 69 2. Isacord 40 0020 
--	--

Overview Stitch Patterns

21026-02_dw 69 x 194 mm / 2.7 x 7.6 inch 7.815

1. Edding 69
2. Applique 1
3. Applique 2
4. Isacord 40 0015
5. Isacord 40 0020
6. Isacord 40 0015

21026-02_cr 104 x 127 mm / 4.1 x 5 inch 150

1. Swarovski 0280
2. Swarovski 0280

12448-09_pw 121 x 161 mm / 4.8 x 6.3 inch 8.265

1. Edding 10
2. Edding 2
3. Edding 8
4. Edding 1

21026-05_dw 118 x 202 mm / 4.6 x 7.9 inch 9.309

1. Edding 9
2. Isacord 40 0020

12448-11_cr 84 x 124 mm / 3.3 x 4.9 inch 174

1. Swarovski 0280
2. Swarovski 0280
3. Swarovski 0280

12448-08_pw 119 x 177 mm / 4.7 x 7 inch 4.540

1. Edding 7

21022-13_dw 106 x 193 mm / 4.2 x 7.6 inch 15.285

1. Edding 34
2. Edding 68
3. Edding 6
4. Applique 1
5. Applique 2
6. Isacord 40 2640
7. Applique 1
8. Applique 2
9. Isacord 40 1352
10. Isacord 40 1600
11. Isacord 40 4111
12. Isacord 40 4103
13. Isacord 40 0017
14. Isacord 40 2830

Be700121 196 x 197 mm / 7.7 x 7.8 inch 2.183

1. Isacord 40 3600
2. Isacord 40 1703

Be700122 119 x 37 mm / 4.7 x 1.5 inch 4.124

1. Isacord 40 5833

Be700123 113 x 206 mm / 4.4 x 8.1 inch 6.090

1. Punch 0004
2. Punch 0007



Be700124 141 x 134 mm 5.6 x 5.3 inch 6.184

1. Isacord 40 2300
2. Isacord 40 3901



Be790906 192 x 196 mm 7.6 x 7.7 inch 21.054

1. Edding 8
2. Edding 3
3. Edding 5
4. Edding 34
5. Edding 69
6. Edding 10
7. Edding 5
8. Edding 9
9. Edding 11
10. Edding 65
11. Edding 12



Be790905 104 x 227 mm 4.1 x 8.9 inch 21.349

1. Edding 34
2. Edding 12
3. Edding 16
4. Edding 10
5. Edding 1



Be790903 181 x 293 mm 7.1 x 11.5 inch 11.366

1. Edding 19



Be790901 182 x 252 mm 7.1 x 9.9 inch 38.392

1. Edding 34
2. Edding 9
3. Edding 33
4. Edding 68
5. Edding 1



Be790909 167 x 322 mm 6.6 x 12.7 inch 20.162

1. Edding 7



Dw05 105 x 94 mm 4.1 x 3.7 inch 13.334

1. Isacord 40 2022
2. Cut 0001
3. Cut 0002
4. Cut 0003
5. Cut 0004
6. Isacord 40 2022



Dw10 119 x 119 mm 4.7 x 4.7 inch 5.939

1. Cut 0001
2. Cut 0002
3. Cut 0003
4. Cut 0004



Dw07 114 x 152 mm 4.5 x 6 inch 198

1. Swarovski 0237



Dw08 206 x 100 mm 8.1 x 3.9 inch 424

1. Swarovski 0501



Index

A

Activate/Deactivate Functions.....	24
Adjust Values.....	24
Adjusting the Presser Foot Position via the Knee Lifter of the Free Hand System.....	36
Adjusting the Upper Thread Tension.....	48
Alphabets.....	97
Altering the Embroidery Design Size Disproportionally.....	138
Altering the Embroidery Design Size Proportionally.....	138
Altering the Stitch Density.....	140
Attaching the Hoop.....	131
Attaching the Knee Lifter of the Free Hand System.....	32
Attaching the Module.....	124

B

BERNINA Dual Feed.....	61
Activating/Deactivating.....	62
Buttonholes.....	99

C

Calibrating the Buttonhole Foot with Slide #3A.....	58
Calibrating the Display.....	56
Calibrating the Embroidery Hoop.....	52
Calling up the Creative Consultant.....	60
Calling Up the Help.....	60
Calling up the Tutorial.....	60
Changing the Color.....	147
Changing the Needle.....	37
Changing the Presser Foot.....	36
Changing the Stitch Plate.....	39
Checking the firmware version.....	155
Child safety lock.....	60
Cleaning the Feed Dog.....	156
Cleaning the Hook.....	157
Combination Mode.....	66, 144
Combining Embroidery Designs.....	144
Cord.....	102
Creating Lettering.....	146

D

Decorative stitches.....	91
Dispose of the Machine.....	168

E

Editing the Lettering.....	147
----------------------------	-----

Embroidery file format.....	122
Embroidery Test.....	122
Energy-saving Mode.....	60
Entering dealer data.....	59
Environmental Protection.....	11
Error Messages.....	160
Explanation of Symbols.....	12

F

Firmware	
Activate/Deactivate Functions.....	24
Adjust Values.....	24
Navigation.....	24
Fitting the Embroidery Needle.....	126
Fitting the Stitch Plate.....	127
Foot Control.....	33
Connecting.....	31
Free Point Positioning.....	143

I

Inserting the Spool Cap.....	34
------------------------------	----

L

Lubricating the Hook.....	157
---------------------------	-----

M

Maintenance and Cleaning.....	156
Moving the hoop to the Back.....	132
Moving the Module for the Sewing Mode.....	132

N

Navigation.....	24
Needle Stop Up/Down (Permanent).....	39
Needle Up/Down	
via the Foot Control.....	33
Needle, Thread, Fabric.....	26
Needle/Thread Combination.....	29
Needles Overview.....	26

O

Overview Embroidery Module.....	119
Overview of Embroidery Designs.....	174

P

Pintucks.....	94
Positioning of Grid Points.....	142



BERNINA recommends threads from *Mettler*[®]

BERNINA International AG | CH-8266 Steckborn Switzerland | www.bernina.com | © Copyright by BERNINA International AG

made to create **BERNINA**

1055835_10A.04
2023-01 EN